

<b>THE NRCA ROOFING MANUAL</b> CONSTRUCTION DETAIL FC-3	<b>RAISED PERIMETER EDGE (FASCIA CAP) WITH FLAT DRIP</b> <ul style="list-style-type: none"> <li>• 24 GA. STEEL</li> <li>• 22 GA. STEEL CLEAT</li> <li>• CONTINUOUS FRONT FACE CLEAT AND GASKETED BACK FACE FASTENER</li> </ul>	<b>ANSI/SPRI ES-1 TESTED RESISTANCE</b>  250 LBS./SQ. FT.	<b>UL-23</b>  10/30/15

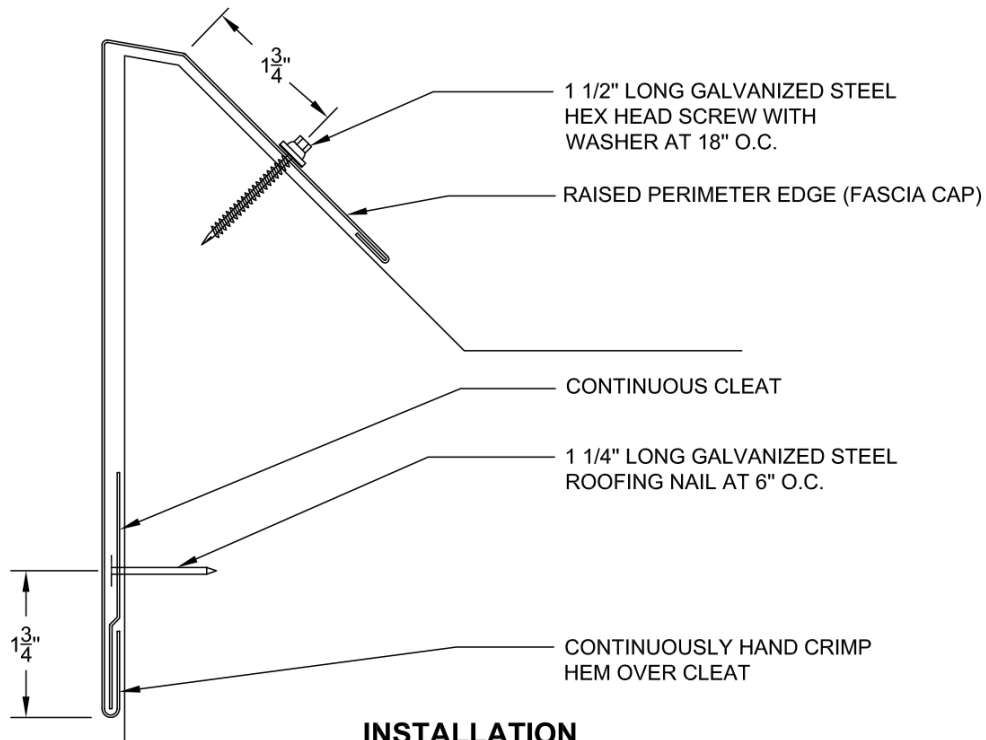

<b>THE NRCA ROOFING MANUAL</b> CONSTRUCTION DETAIL FC-4	<b>RAISED PERIMETER EDGE (FASCIA CAP) WITH FLAT DRIP</b> <ul style="list-style-type: none"> <li>• 24 GA. STEEL</li> <li>• 22 GA. STEEL CLEAT</li> <li>• CONTINUOUS FRONT FACE CLEAT AND GASKETED BACK FACE FASTENER</li> </ul>	<b>ANSI/SPRI ES-1 TESTED RESISTANCE</b>	<b>UL-23A</b>  10/30/15
		250 LBS./SQ. FT.	

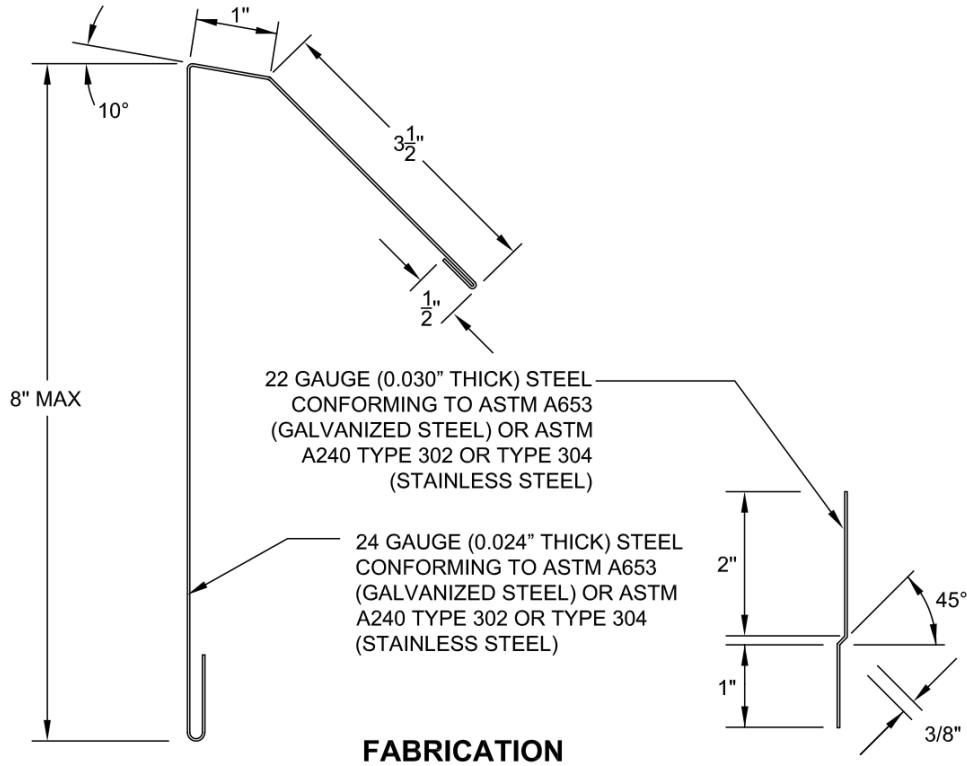
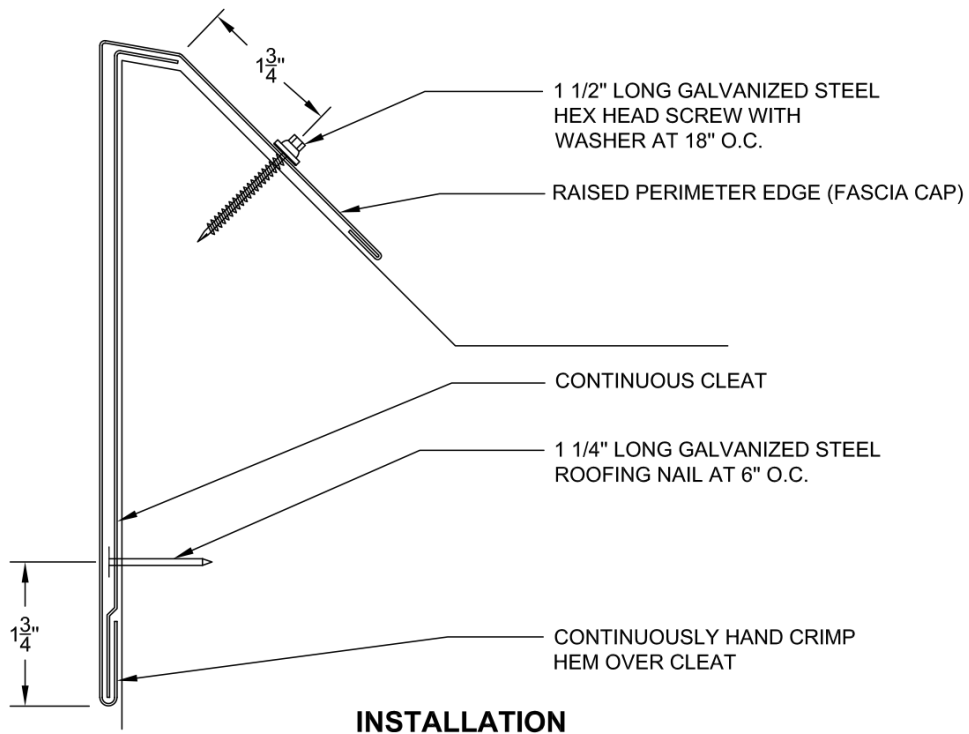
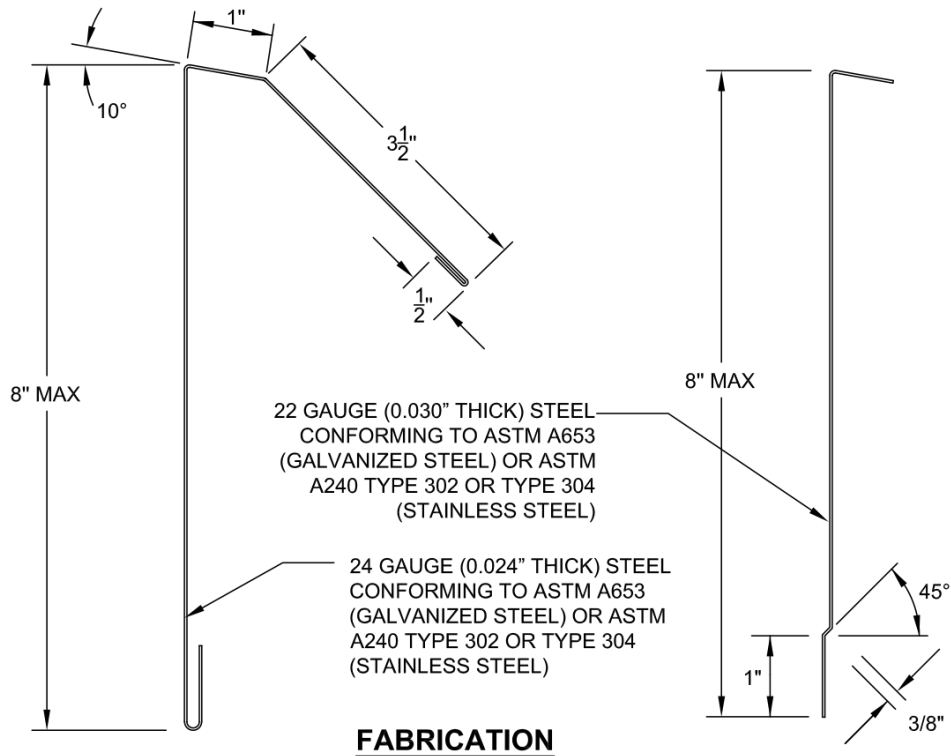

<b>THE NRCA ROOFING MANUAL</b> CONSTRUCTION DETAIL FC-3	<b>RAISED PERIMETER EDGE (FASCIA CAP) WITH FLAT DRIP</b> <ul style="list-style-type: none"> <li>• 0.040" ALUMINUM</li> <li>• 0.040" ALUMINUM CLEAT</li> <li>• CONTINUOUS FRONT FACE CLEAT AND GASKETED BACK FACE FASTENER</li> </ul>	<b>ANSI/SPRI ES-1 TESTED RESISTANCE</b>  330 LBS./SQ. FT.	<b>UL-24</b>  2/6/17

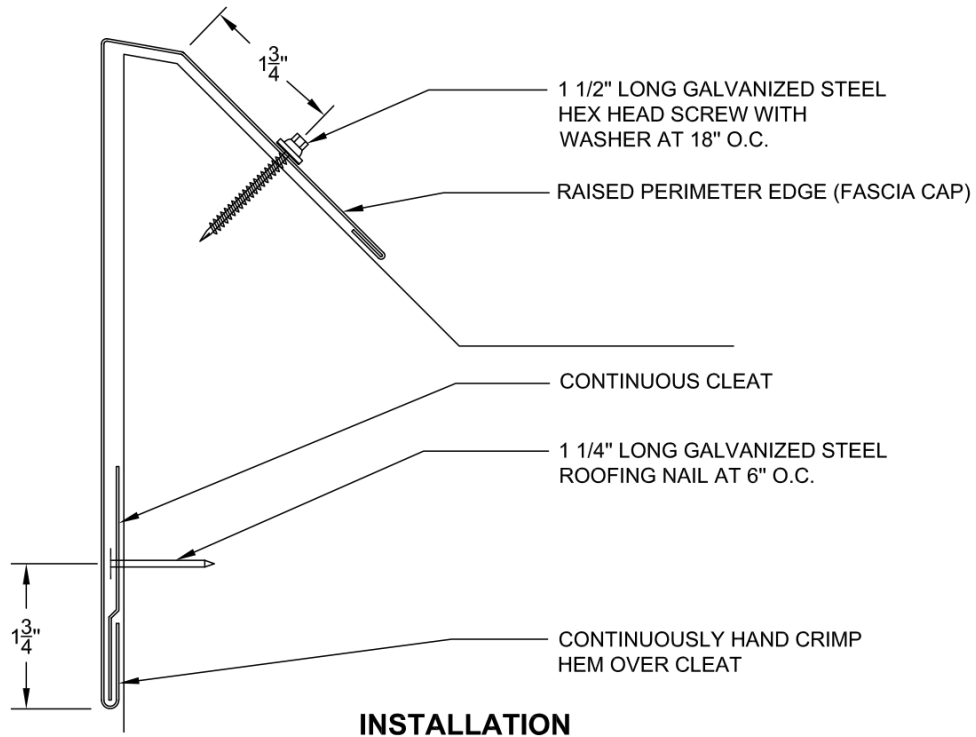
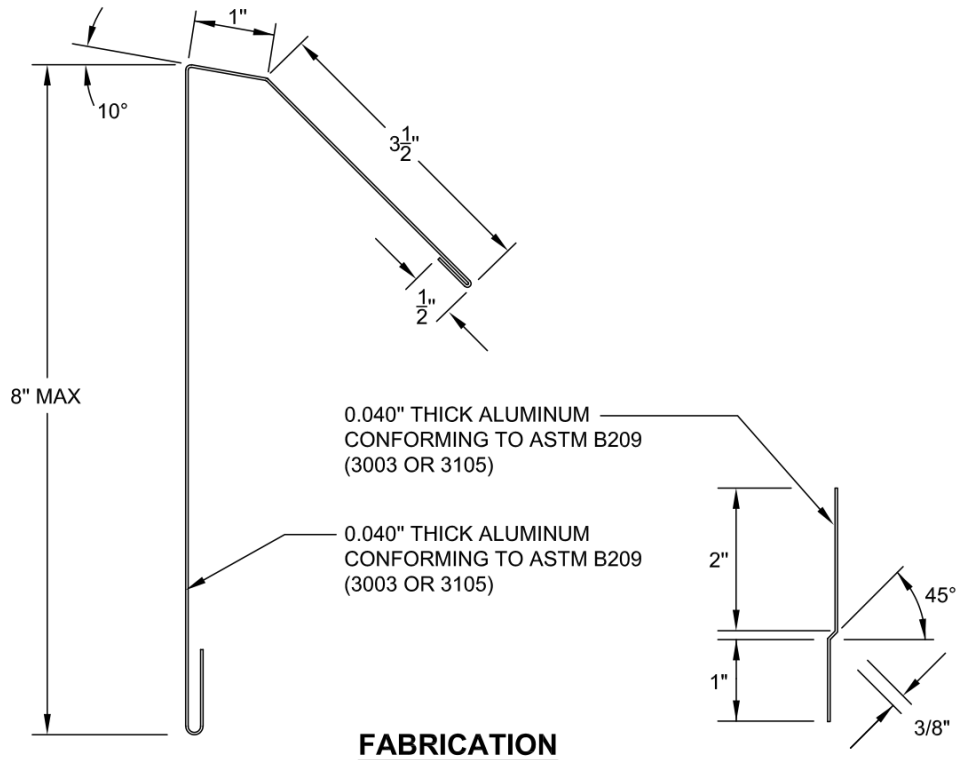

<b>THE NRCA ROOFING MANUAL</b> CONSTRUCTION DETAIL FC-4	<b>RAISED PERIMETER EDGE (FASCIA CAP) WITH FLAT DRIP</b> <ul style="list-style-type: none"> <li>• 0.040" ALUMINUM</li> <li>• 0.040" ALUMINUM CLEAT</li> <li>• CONTINUOUS FRONT FACE CLEAT AND GASKETED BACK FACE FASTENER</li> </ul>	<b>ANSI/SPRI ES-1 TESTED RESISTANCE</b>  330 LBS./SQ. FT.	<b>UL-24A</b>  2/6/17

