

<b>THE NRCA ROOFING MANUAL</b> CONSTRUCTION DETAILS FC-1	<b>RAISED PERIMETER EDGE (FASCIA CAP)</b> <ul style="list-style-type: none"> <li>• 24 GA. STEEL</li> <li>• 22 GA. STEEL CLEAT</li> <li>• CONTINUOUS FRONT FACE CLEAT AND GASKETED BACK FACE FASTENER</li> </ul>	<b>ANSI/SPRI ES-1 TESTED RESISTANCE</b>	<b>UL-20</b>  10/30/15
		170 LBS./SQ. FT.	

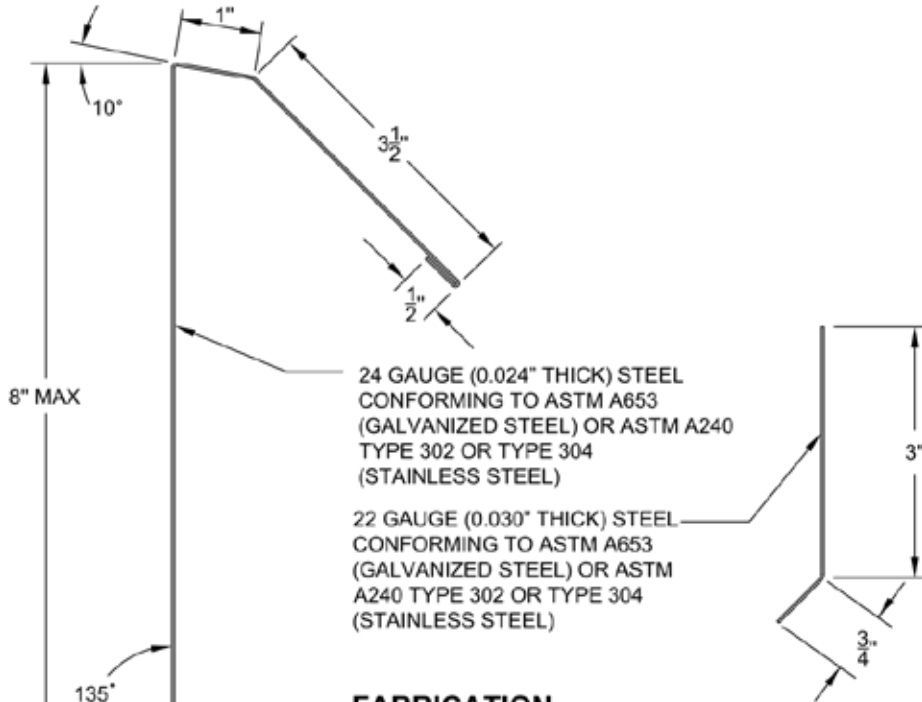

**FABRICATION**

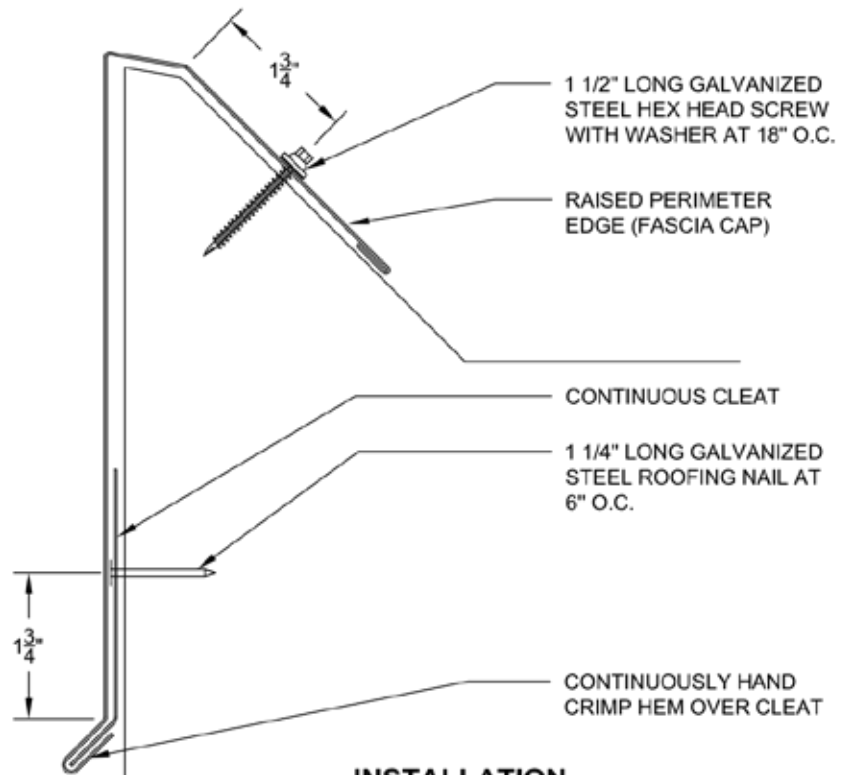

**INSTALLATION**



<b>THE NRCA ROOFING MANUAL</b> CONSTRUCTION DETAIL FC-1	<b>RAISED PERIMETER EDGE (FASCIA CAP)</b> <ul style="list-style-type: none"> <li>• 0.040" ALUMINUM</li> <li>• 0.040" ALUMINUM CLEAT</li> <li>• CONTINUOUS FRONT FACE CLEAT AND GASKETED BACK FACE FASTENER</li> </ul>	<b>ANSI/SPRI ES-1 TESTED RESISTANCE</b>	<b>UL-21</b>  2/6/17
		140 LBS./SQ. FT.	

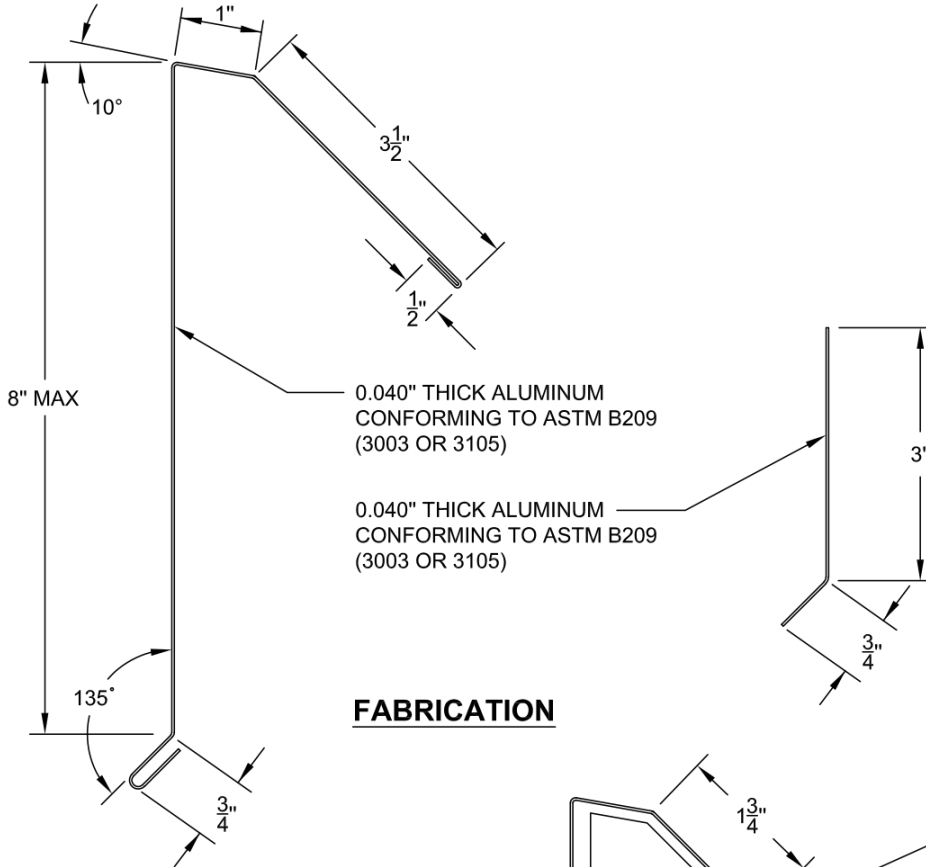

**FABRICATION**

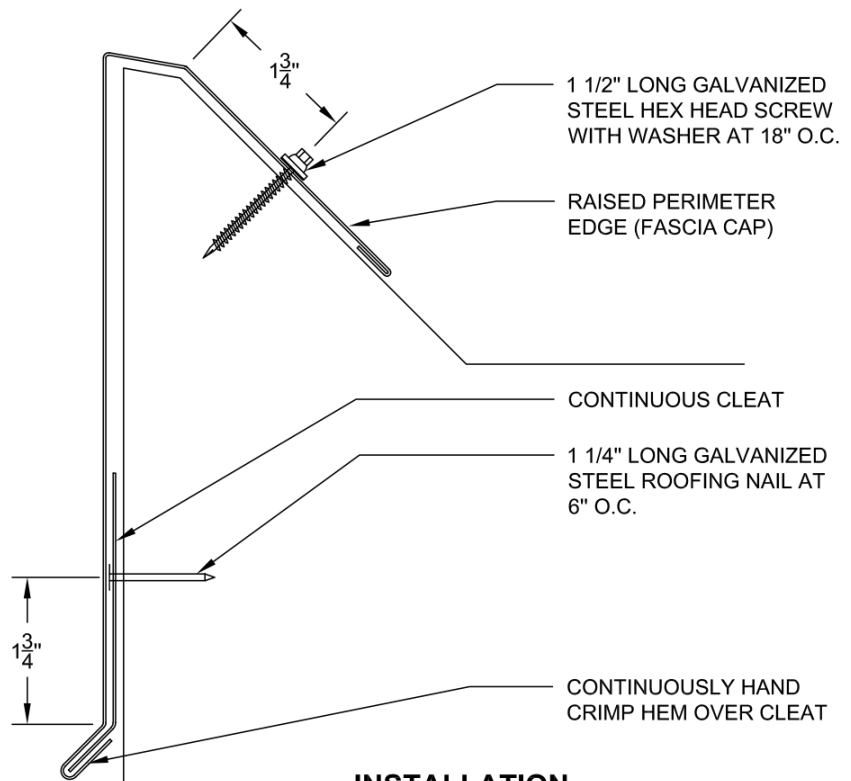

**INSTALLATION**

<b>THE NRCA ROOFING MANUAL</b> CONSTRUCTION DETAIL FC-2	<b>RAISED PERIMETER EDGE (FASCIA CAP)</b> <ul style="list-style-type: none"> <li>• 0.040" ALUMINUM</li> <li>• 0.040" ALUMINUM CLEAT</li> <li>• CONTINUOUS FRONT FACE CLEAT AND GASKETED BACK FACE FASTENER</li> </ul>	<b>ANSI/SPRI ES-1 TESTED RESISTANCE</b>	<b>UL-21A</b>  2/6/17
		140 LBS./SQ. FT.	

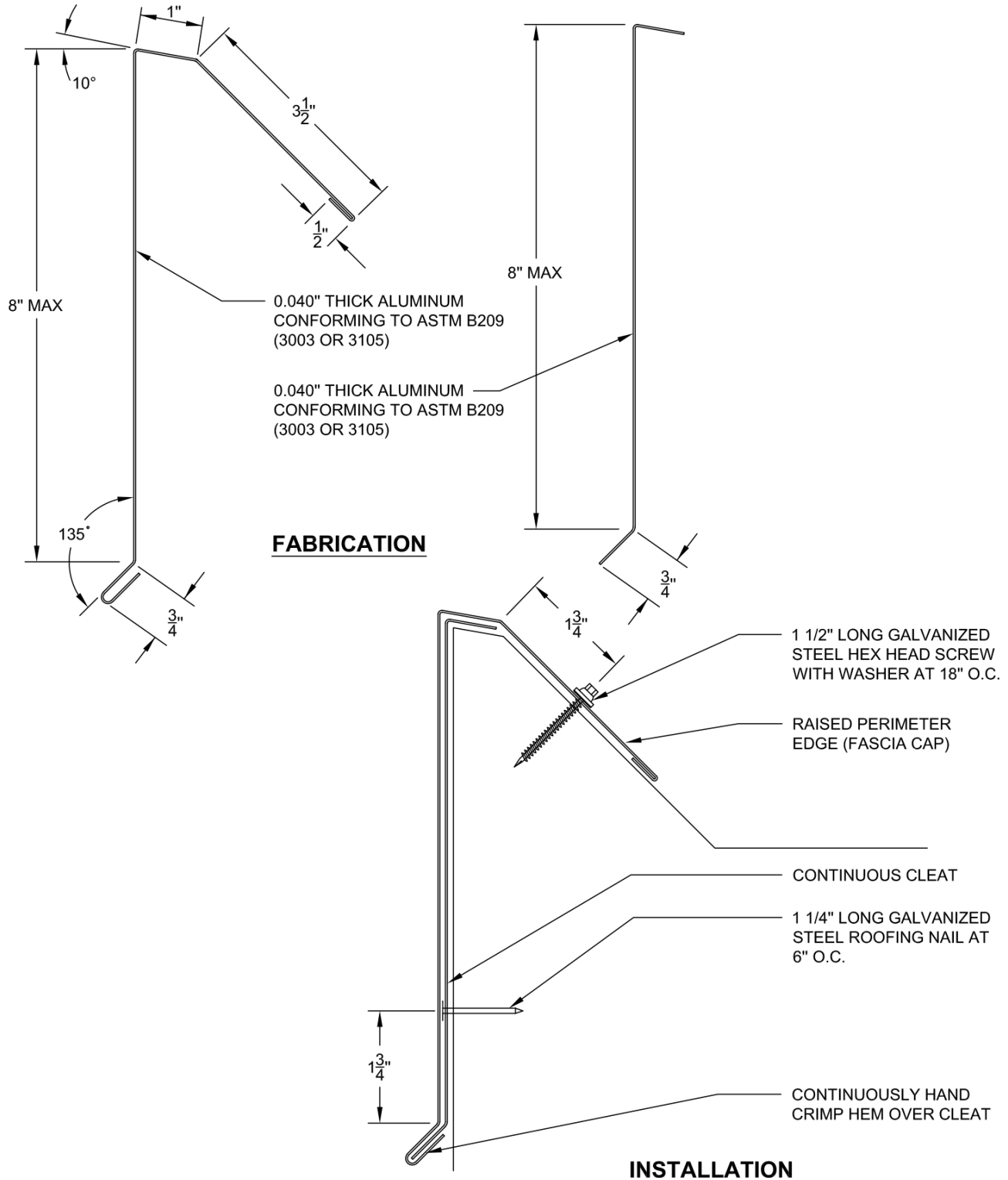

<b>THE NRCA ROOFING MANUAL</b> CONSTRUCTION DETAIL FC-1	<b>RAISED PERIMETER EDGE (FASCIA CAP)</b> <ul style="list-style-type: none"> <li>• 0.040" ALUMINUM</li> <li>• 0.050" ALUMINUM CLEAT</li> <li>• CONTINUOUS FRONT FACE CLEAT AND GASKETED BACK FACE FASTENER</li> </ul>	<b>ANSI/SPRI ES-1 TESTED RESISTANCE</b>	<b>UL-22</b>  2/6/17
		230 LBS./SQ. FT.	

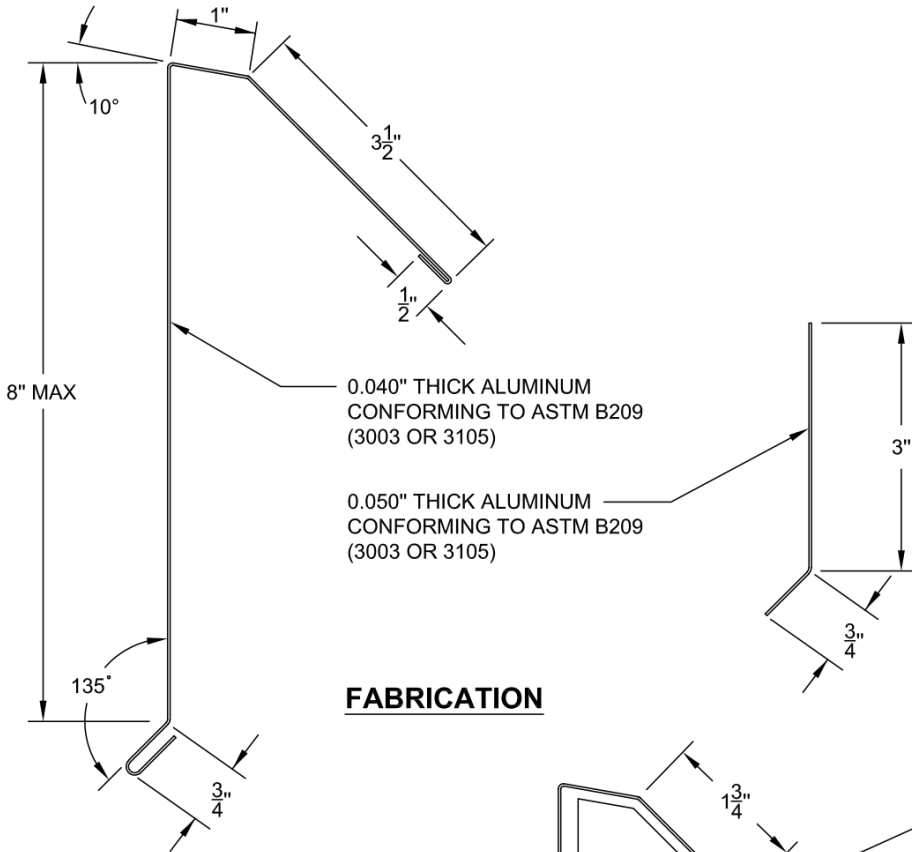

**FABRICATION**

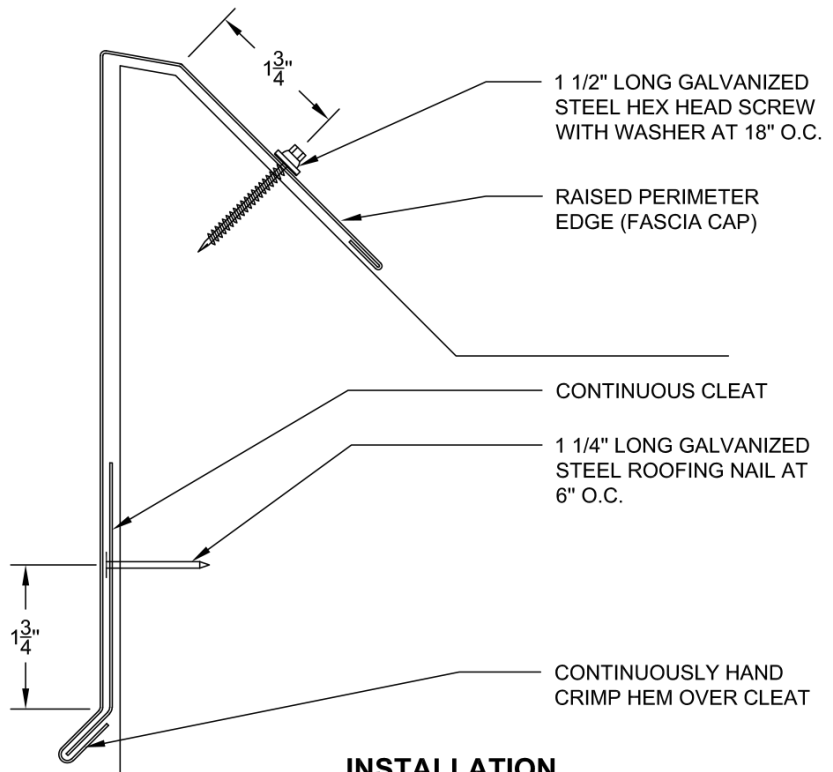

**INSTALLATION**

<b>THE NRCA ROOFING MANUAL</b> CONSTRUCTION DETAIL FC-2	<b>RAISED PERIMETER EDGE (FASCIA CAP)</b> <ul style="list-style-type: none"> <li>• 0.040" ALUMINUM</li> <li>• 0.050" ALUMINUM CLEAT</li> <li>• CONTINUOUS FRONT FACE CLEAT AND GASKETED BACK FACE FASTENER</li> </ul>	<b>ANSI/SPRI ES-1 TESTED RESISTANCE</b>	<b>UL-22A</b>  2/6/17
		230 LBS./SQ. FT.	

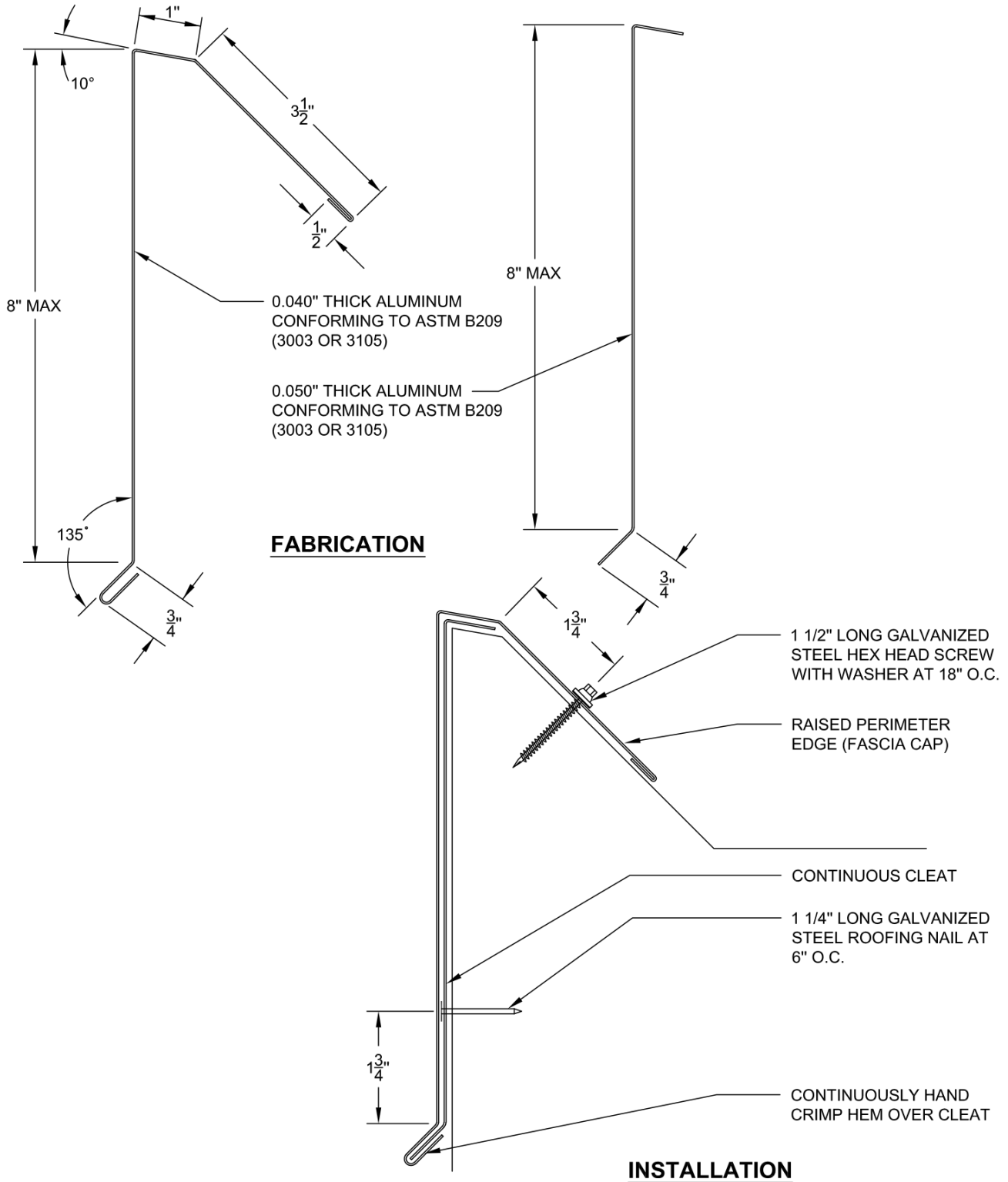

<b>THE NRCA ROOFING MANUAL</b> CONSTRUCTION DETAILS	<b>RAISED PERIMETER EDGE (FASCIA CAP)</b> • 24 GA. STEEL • 22 GA. STEEL CANT	<b>ANSI/SPRI ES-1 TESTED RESISTANCE</b>  190 LBS./SQ. FT.	<b>UL-36</b>  10/30/15

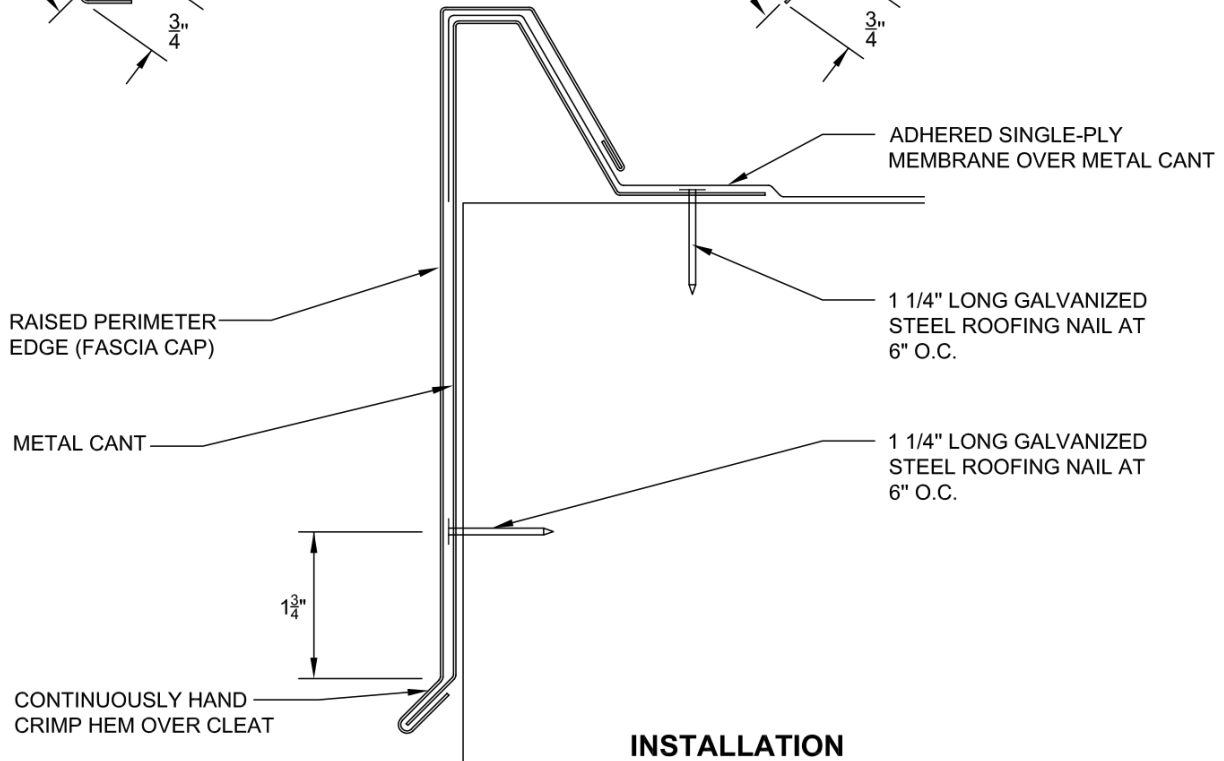
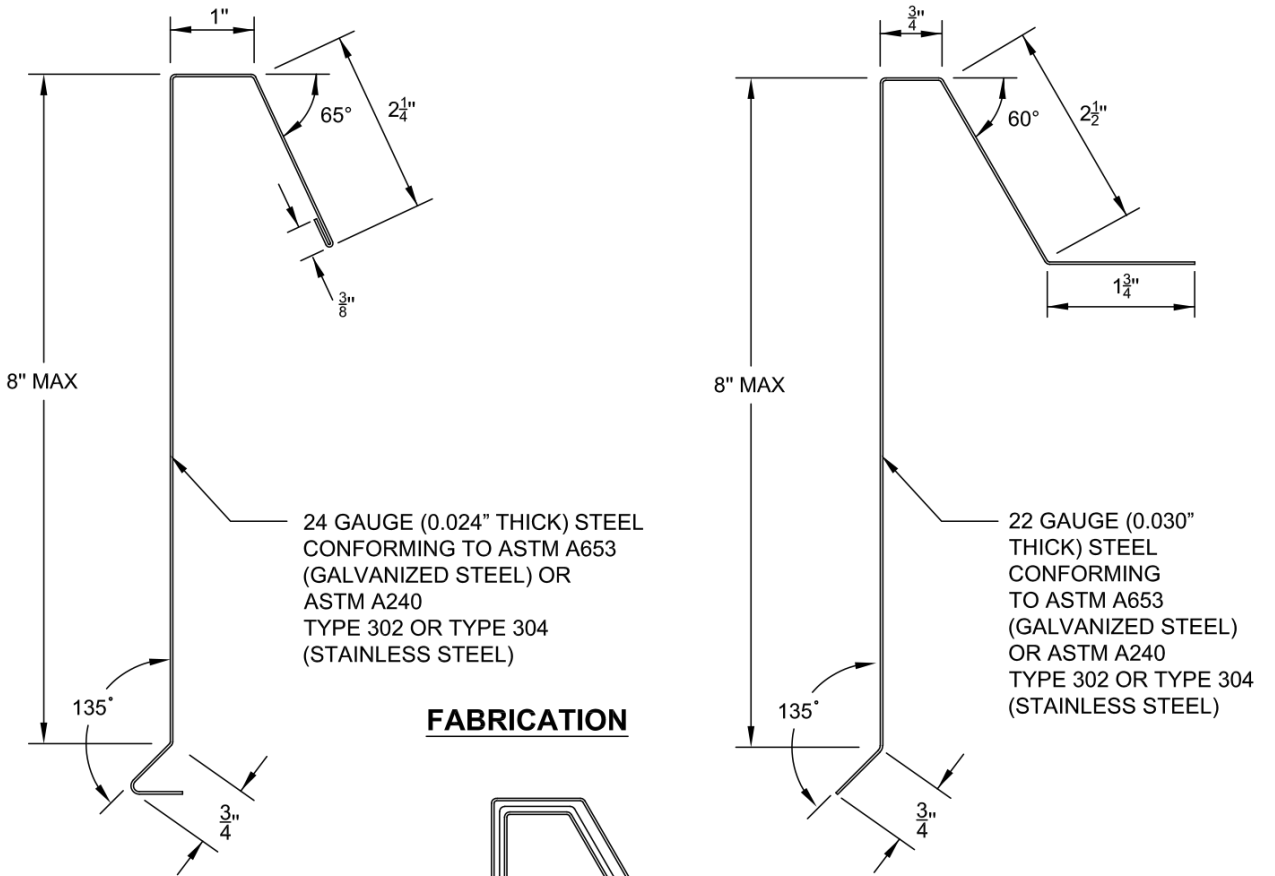

<b>THE NRCA ROOFING MANUAL</b> CONSTRUCTION DETAILS	<b>RAISED PERIMETER EDGE (FASCIA CAP)</b> • 0.040 ALUMINUM • 0.050 ALUMINUM CANT	<b>ANSI/SPRI ES-1 TESTED RESISTANCE</b>  200 LBS./SQ. FT.	<b>UL-37</b>  5/27/16

