

<b>THE NRCA ROOFING MANUAL</b> CONSTRUCTION DETAIL C-1	<b>COPING</b> • 24 GA. STEEL • 22 GA. STEEL CLEAT • CONTINUOUS FRONT FACE CLEAT AND GASKETED BACK FACE FASTENER	<b>ANSI/SPRI ES-1 TESTED RESISTANCE</b>	<b>UL-4</b>  10/30/15
		OUTWARD      UPWARD 265 LBS./SQ. FT.    440 LBS./SQ. FT.	

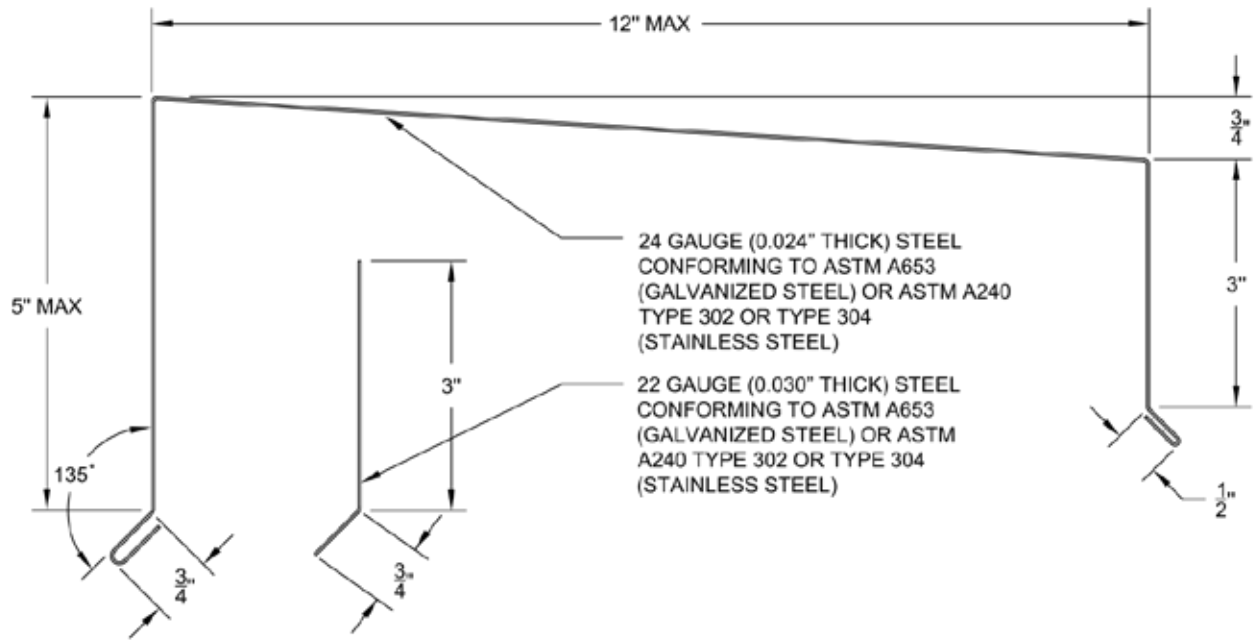

**FABRICATION**

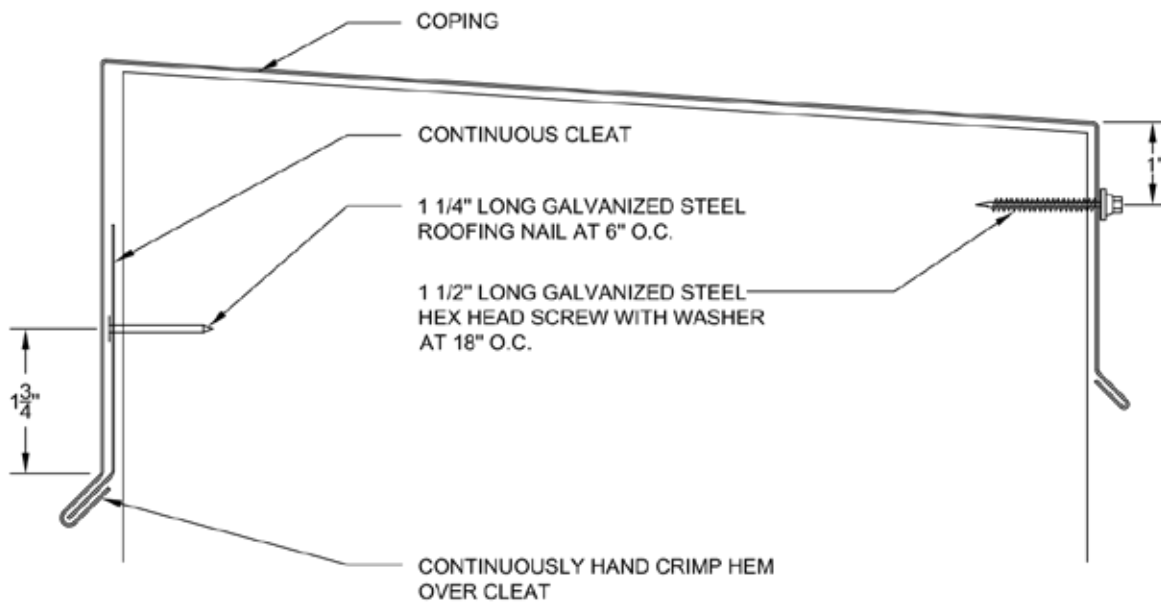

**INSTALLATION**

<b>THE NRCA ROOFING MANUAL</b> CONSTRUCTION DETAIL C-2	<b>COPING</b> • 24 GA. STEEL • 22 GA. STEEL CLEAT • CONTINUOUS FRONT FACE CLEAT AND GASKETED BACK FACE FASTENER	<b>ANSI/SPRI ES-1 TESTED RESISTANCE</b>		<b>UL-4A</b>  10/30/15
		OUTWARD 265 LBS./SQ. FT.	UPWARD 440 LBS./SQ. FT.	

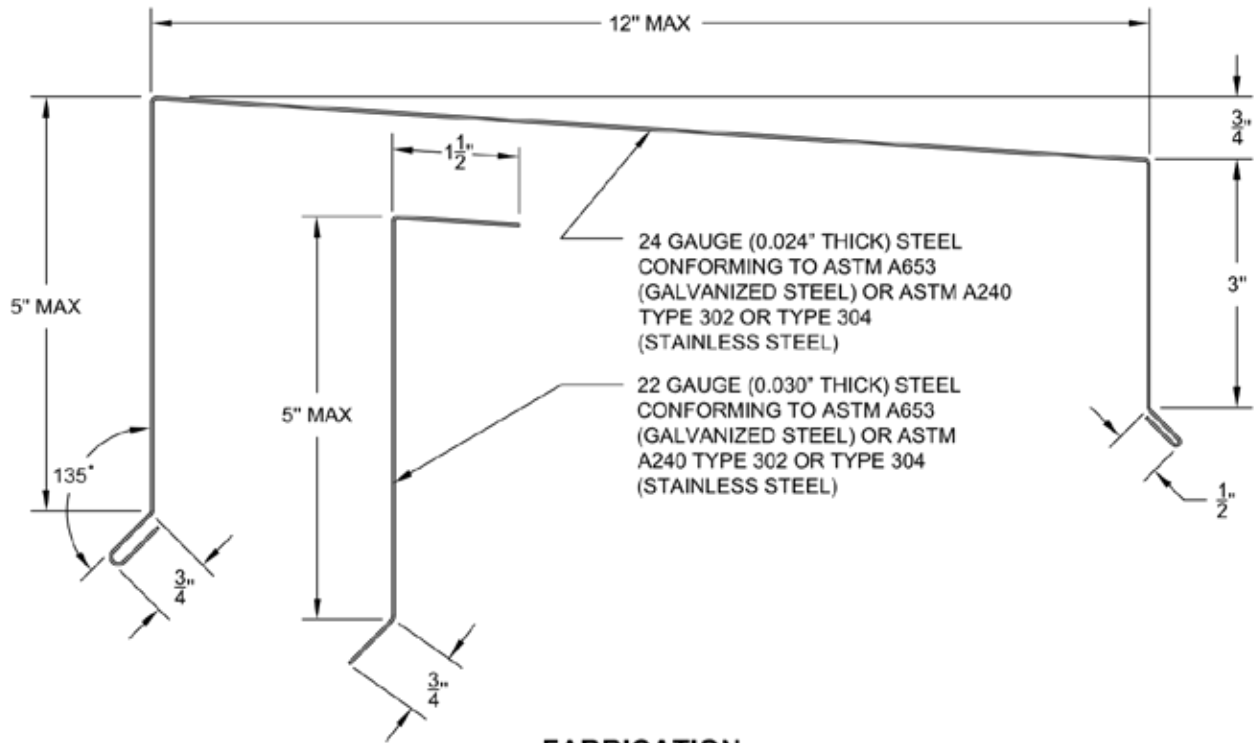

**FABRICATION**

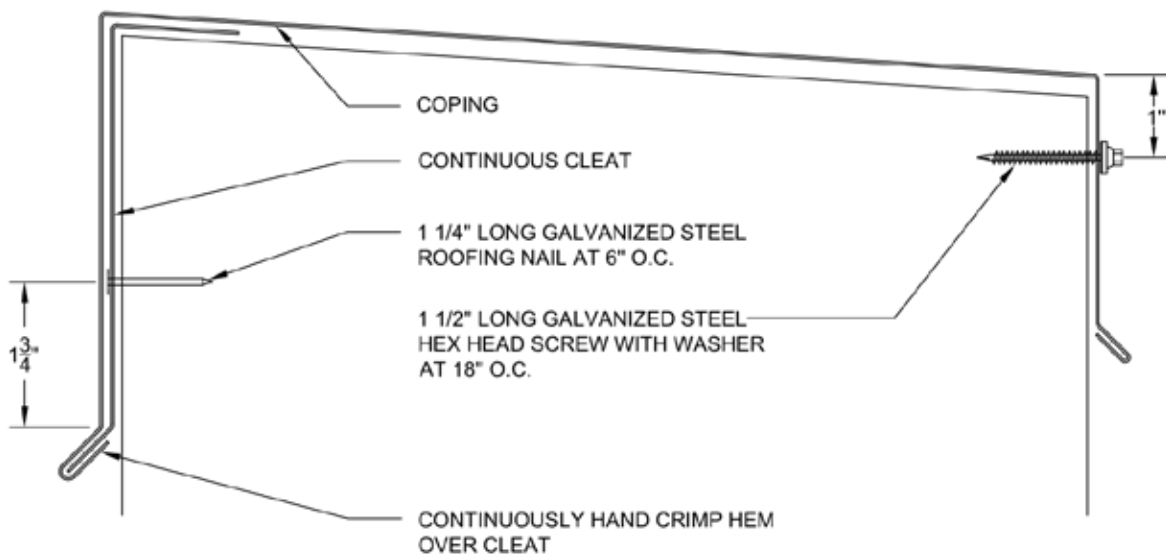

**INSTALLATION**

<b>THE NRCA ROOFING MANUAL</b> CONSTRUCTION DETAIL C-3	<b>COPING</b> <ul style="list-style-type: none"> <li>• 24 GA. STEEL</li> <li>• 22 GA. STEEL CLEAT</li> <li>• CONTINUOUS FRONT FACE CLEAT AND GASKETED BACK FACE FASTENER</li> </ul>	<b>ANSI/SPRI ES-1 TESTED RESISTANCE</b>		<b>UL-4B</b>  10/30/15
		OUTWARD 214 LBS./SQ. FT.	UPWARD 350 LBS./SQ. FT.	

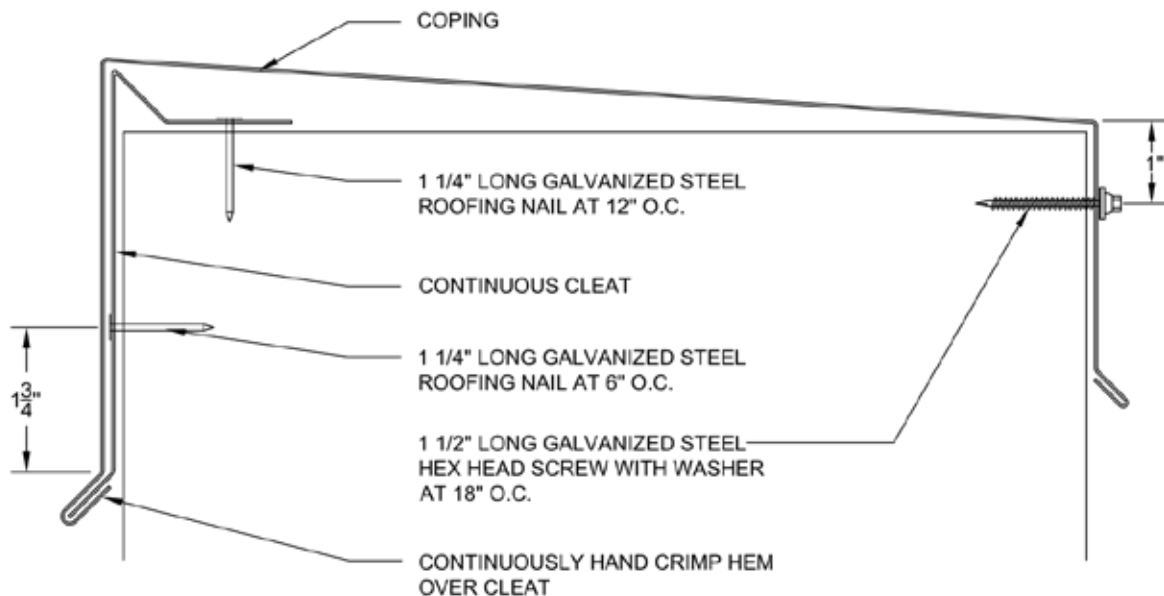
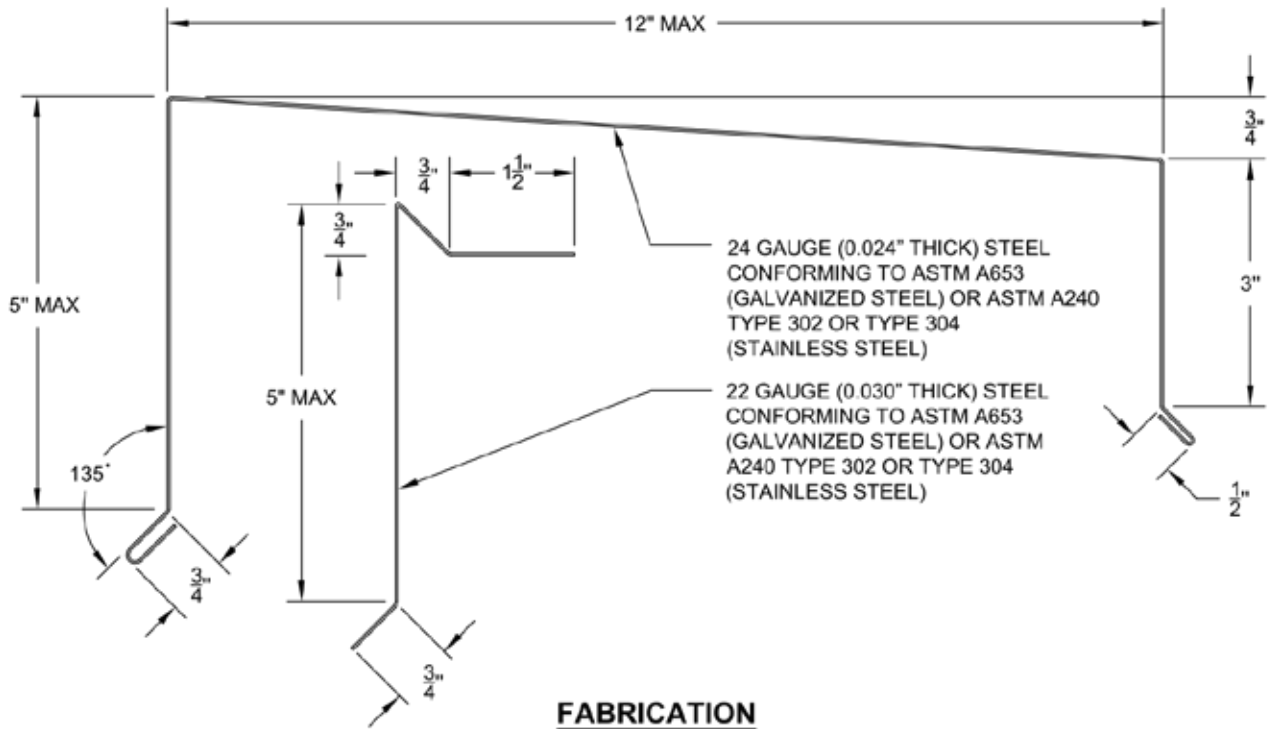

<b>THE NRCA ROOFING MANUAL</b> CONSTRUCTION DETAIL C-1	<b>COPING</b> • 22 GA. STEEL • 20 GA. STEEL CLEAT • CONTINUOUS FRONT FACE CLEAT AND GASKETED BACK FACE FASTENER	<b>ANSI/SPRI ES-1 TESTED RESISTANCE</b>		<b>UL-5</b>  10/30/15
		OUTWARD 175 LBS./SQ. FT.	UPWARD 290 LBS./SQ. FT.	

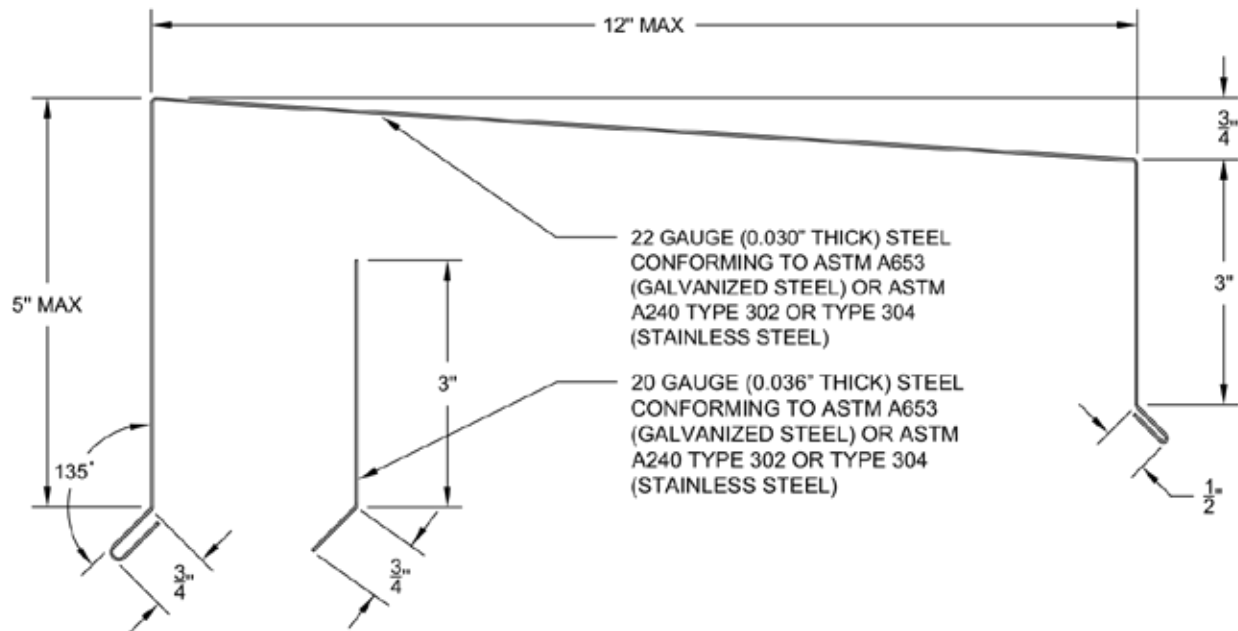

**FABRICATION**

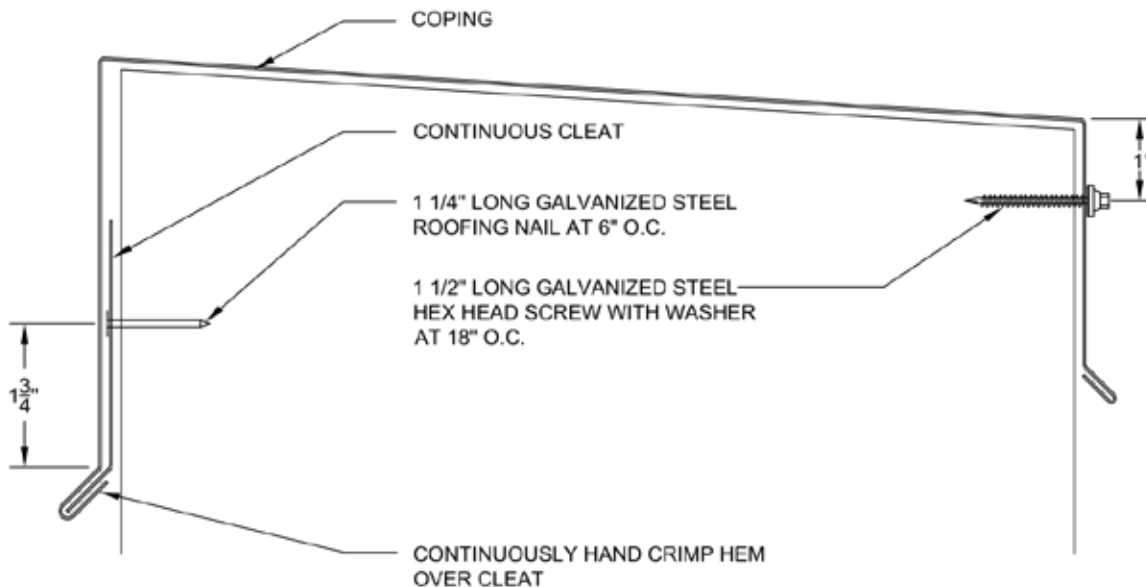

**INSTALLATION**

<b>THE NRCA ROOFING MANUAL</b> CONSTRUCTION DETAIL C-2	<b>COPING</b> • 22 GA. STEEL • 20 GA. STEEL CLEAT • CONTINUOUS FRONT FACE CLEAT AND GASKETED BACK FACE FASTENER	<b>ANSI/SPRI ES-1 TESTED RESISTANCE</b>		<b>UL-5A</b>  10/30/15
		OUTWARD 175 LBS./SQ. FT.	UPWARD 290 LBS./SQ. FT.	

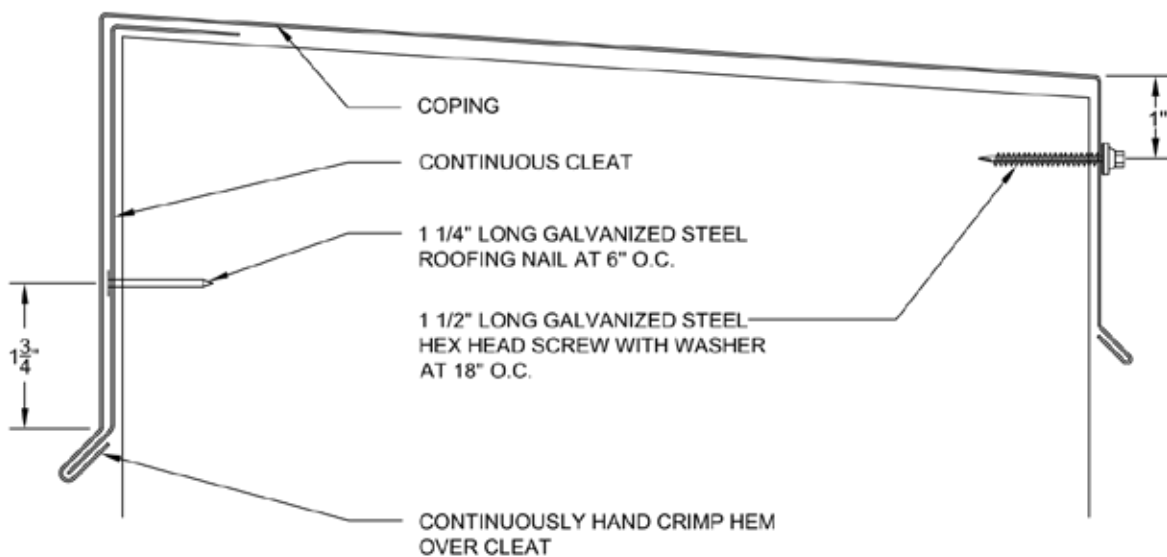
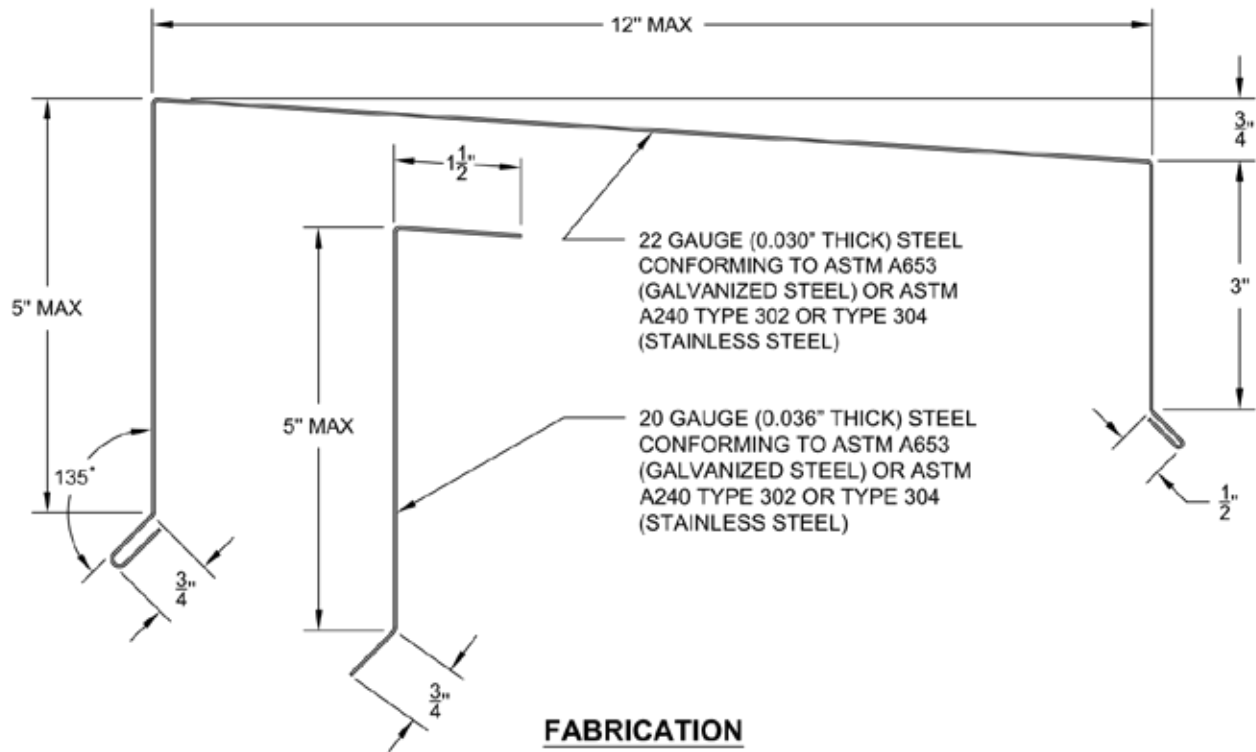

<b>THE NRCA ROOFING MANUAL</b> CONSTRUCTION DETAIL C-1	<b>COPING</b> <ul style="list-style-type: none"> <li>• 0.040" ALUMINUM</li> <li>• 0.040" ALUMINUM CLEAT</li> <li>• CONTINUOUS FRONT FACE CLEAT AND GASKETED BACK FACE FASTENER</li> </ul>	<b>ANSI/SPRI ES-1 TESTED RESISTANCE</b>		<b>UL-6</b>  2/6/17
		OUTWARD 95 LBS./SQ. FT.	UPWARD 160 LBS./SQ. FT.	

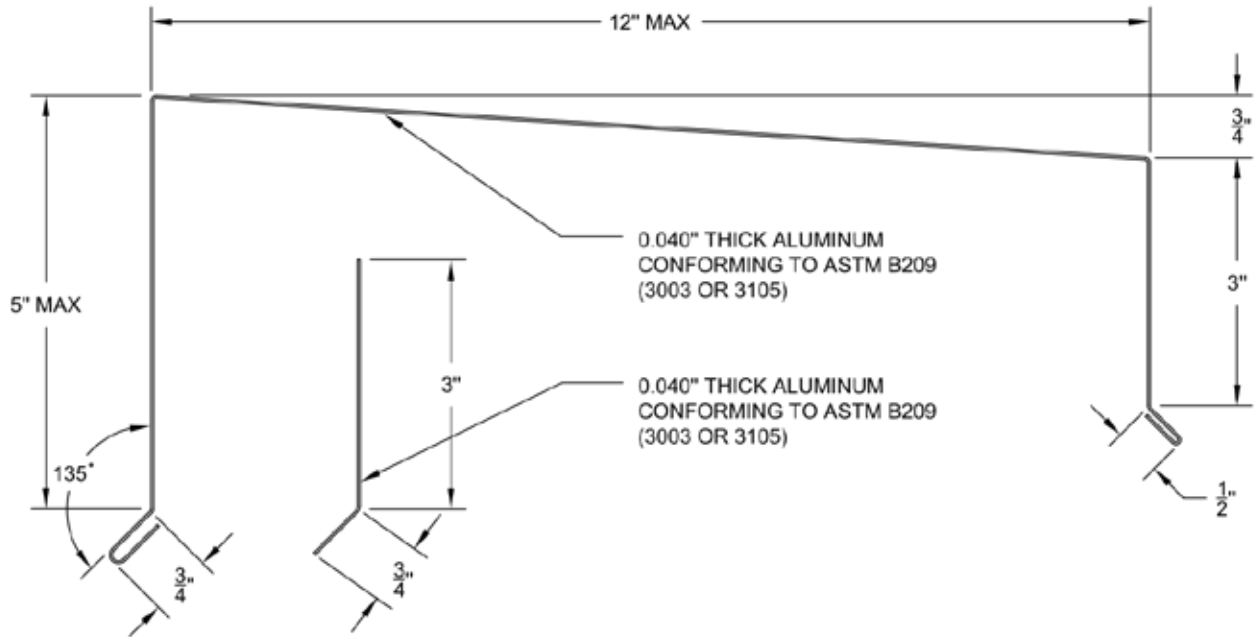

**FABRICATION**

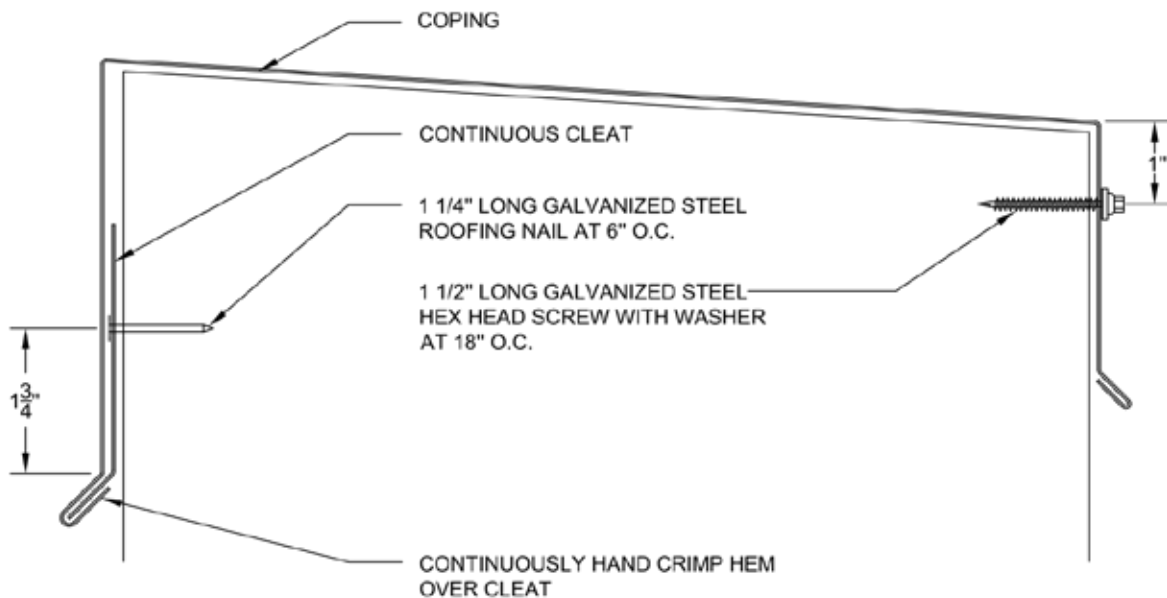

**INSTALLATION**

<b>THE NRCA ROOFING MANUAL</b> CONSTRUCTION DETAIL C-2	<b>COPING</b> <ul style="list-style-type: none"> <li>• 0.040" ALUMINUM</li> <li>• 0.040" ALUMINUM CLEAT</li> <li>• CONTINUOUS FRONT FACE CLEAT AND GASKETED BACK FACE FASTENER</li> </ul>	<b>ANSI/SPRI ES-1 TESTED RESISTANCE</b>		<b>UL-6A</b>  2/6/17
		OUTWARD 95 LBS./SQ. FT.	UPWARD 160 LBS./SQ. FT.	

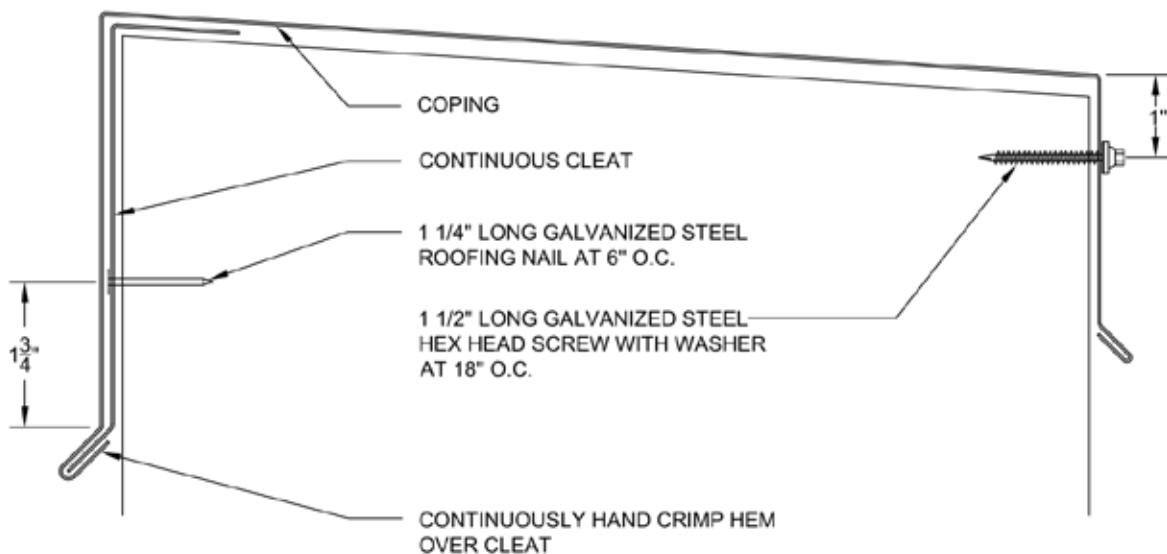
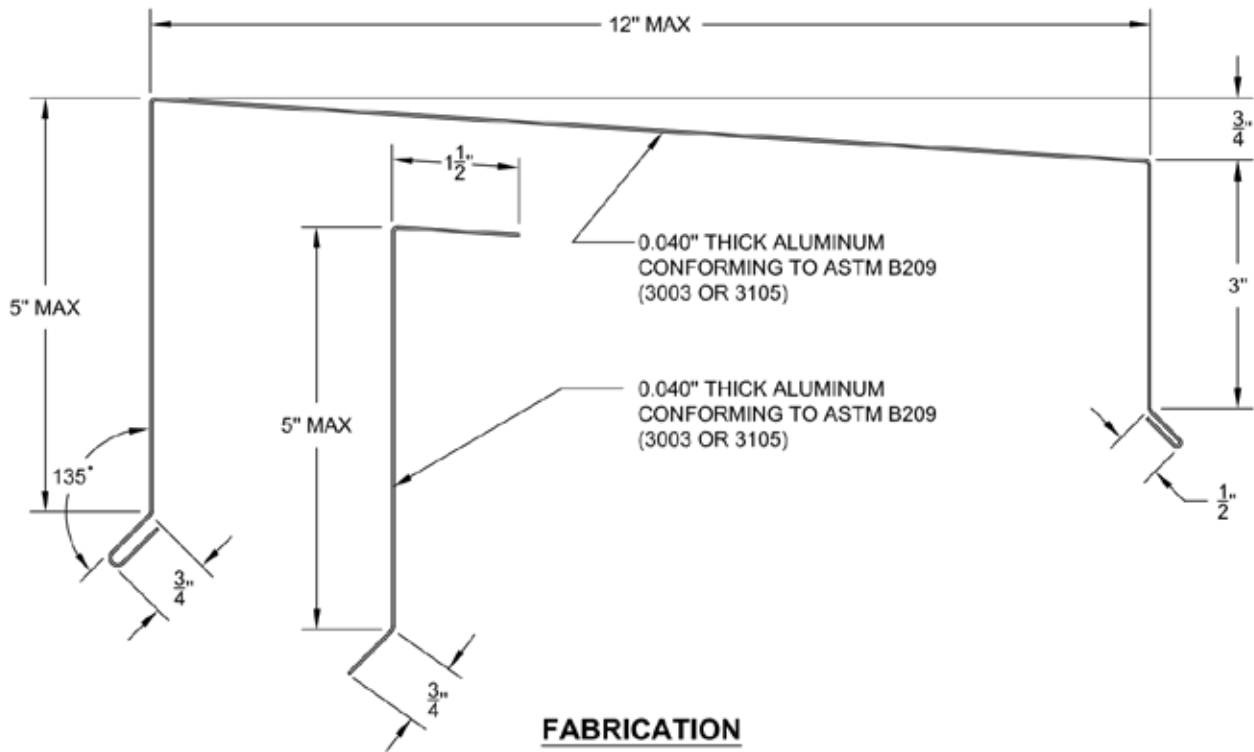

<b>THE NRCA ROOFING MANUAL</b> CONSTRUCTION DETAIL C-3	<b>COPING</b> <ul style="list-style-type: none"> <li>• 0.040" ALUMINUM</li> <li>• 0.050" ALUMINUM CLEAT</li> <li>• CONTINUOUS FRONT FACE CLEAT AND GASKETED BACK FACE FASTENER</li> </ul>	<b>ANSI/SPRI ES-1 TESTED RESISTANCE</b>		<b>UL-6B</b>  2/6/17
		OUTWARD 202 LBS./SQ. FT.	UPWARD 330 LBS./SQ. FT.	

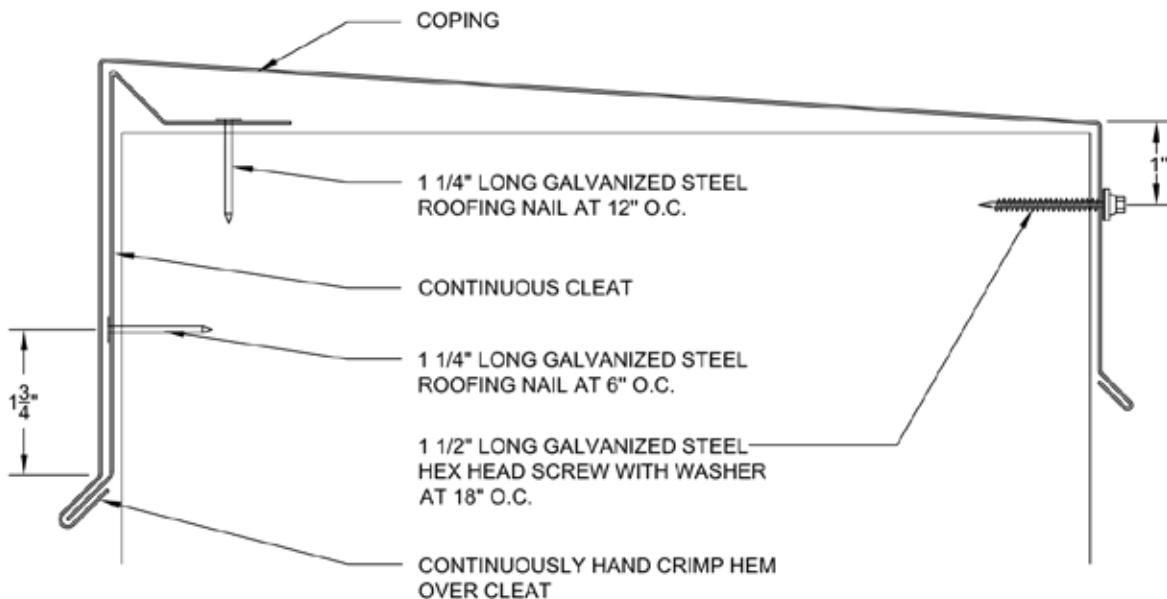
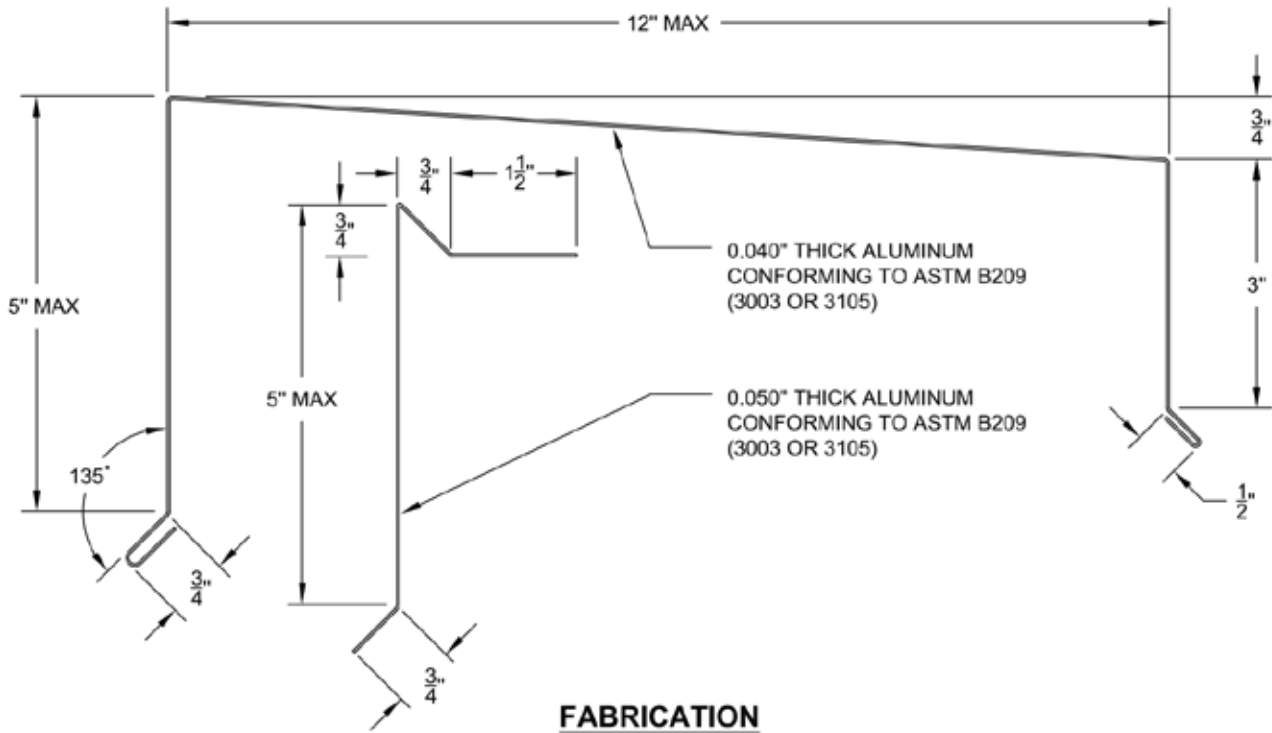



<b>THE NRCA ROOFING MANUAL</b> CONSTRUCTION DETAIL C-1	<b>COPING</b> <ul style="list-style-type: none"> <li>• 0.050" ALUMINUM</li> <li>• 0.050" ALUMINUM CLEAT</li> <li>• CONTINUOUS FRONT FACE CLEAT AND GASKETED BACK FACE FASTENER</li> </ul>	<b>ANSI/SPRI ES-1 TESTED RESISTANCE</b>		<b>UL-7</b>  2/6/17
		OUTWARD 180 LBS./SQ. FT.	UPWARD 300 LBS./SQ. FT.	

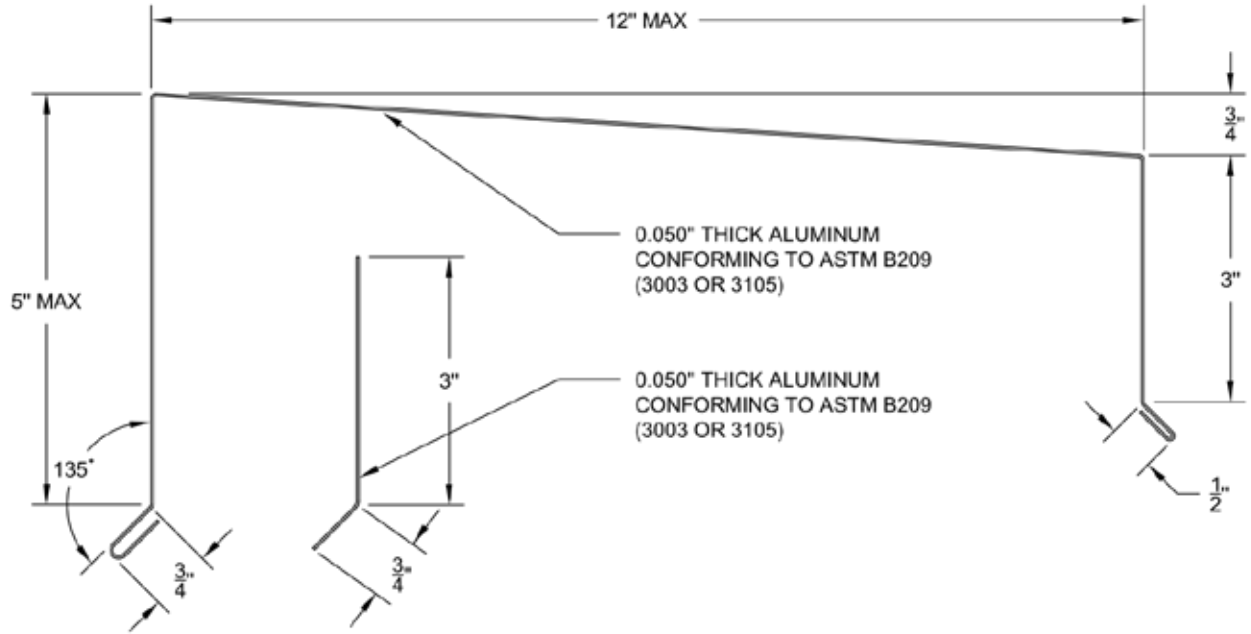

**FABRICATION**

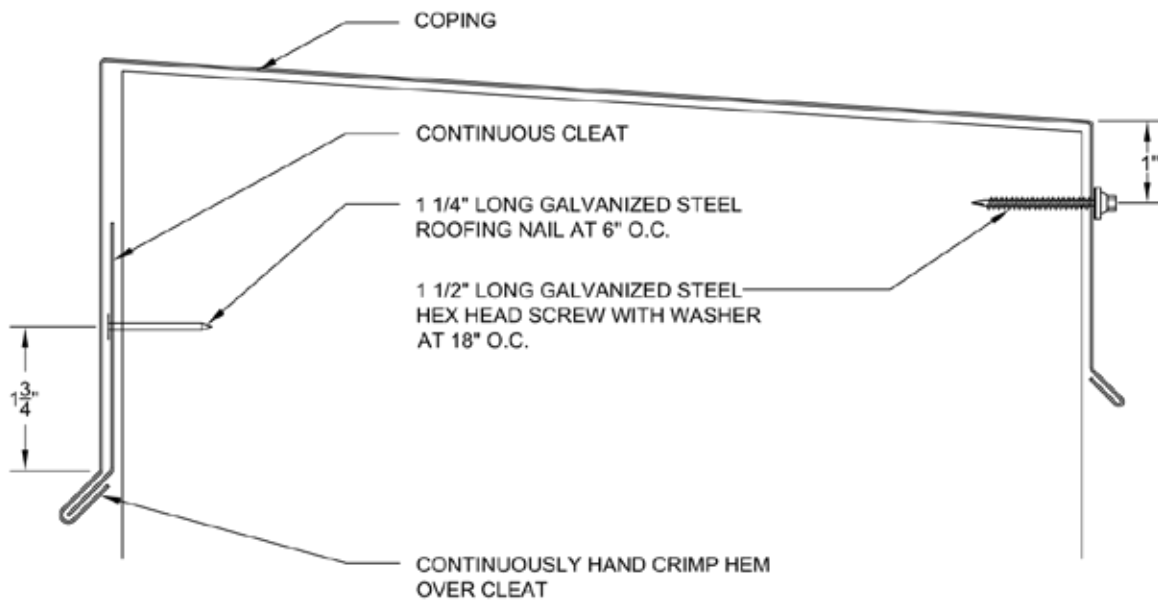

**INSTALLATION**

<b>THE NRCA ROOFING MANUAL</b> CONSTRUCTION DETAIL C-2	<b>COPING</b> <ul style="list-style-type: none"> <li>• 0.050" ALUMINUM</li> <li>• 0.050" ALUMINUM CLEAT</li> <li>• CONTINUOUS FRONT FACE CLEAT AND GASKETED BACK FACE FASTENER</li> </ul>	<b>ANSI/SPRI ES-1 TESTED RESISTANCE</b>		<b>UL-7A</b>  2/6/17
		OUTWARD 180 LBS./SQ. FT.	UPWARD 300 LBS./SQ. FT.	

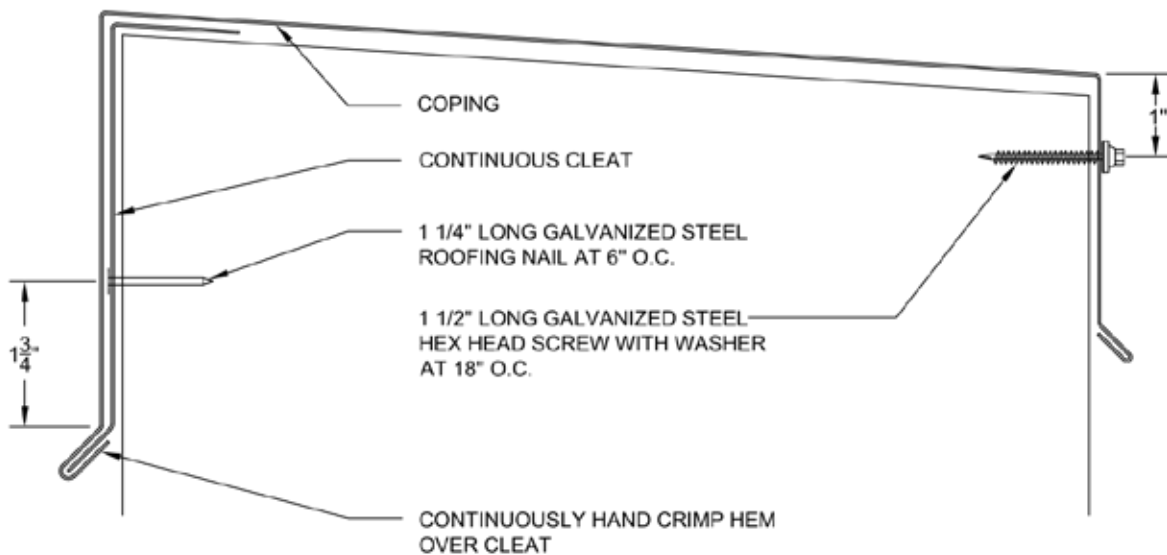
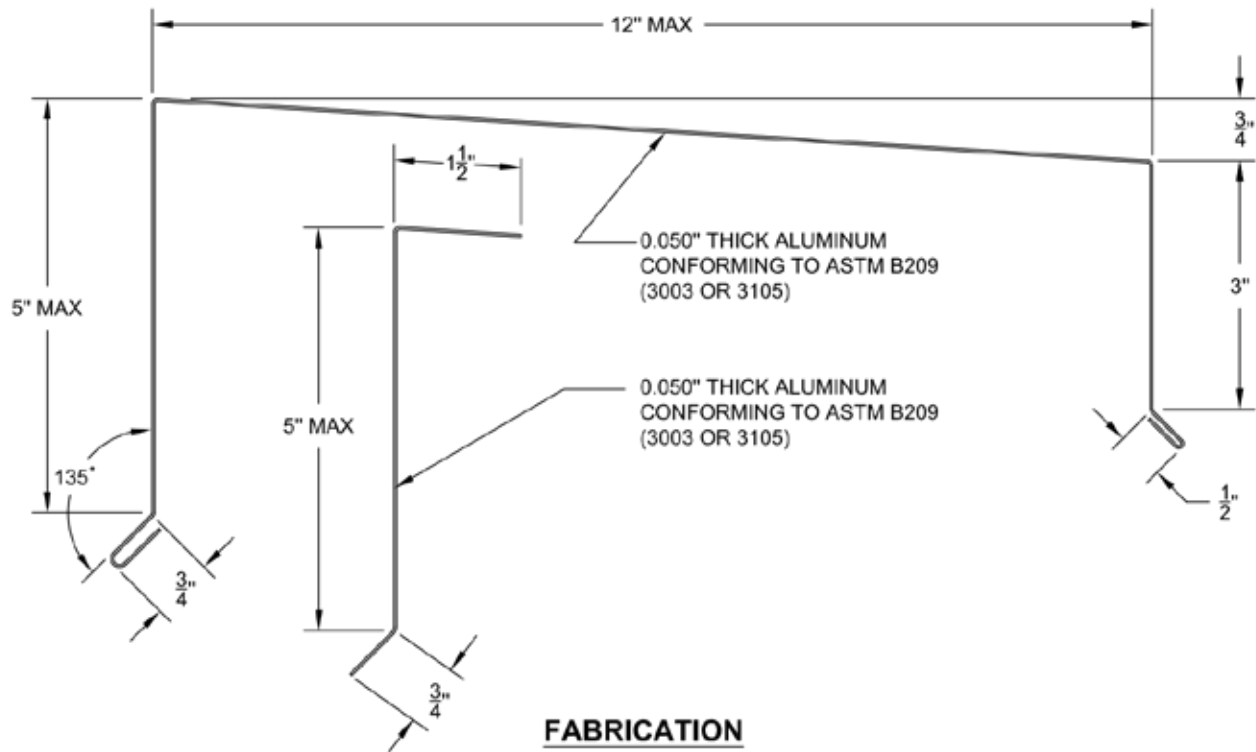

<b>THE NRCA ROOFING MANUAL</b> CONSTRUCTION DETAIL C-1	<b>COPING</b> <ul style="list-style-type: none"> <li>• 16 OZ. COPPER</li> <li>• 24 GA. STAINLESS STEEL CLEAT</li> <li>• CONTINUOUS FRONT FACE CLEAT AND GASKETED BACK FACE FASTENER</li> </ul>	<b>ANSI/SPRI ES-1 TESTED RESISTANCE</b>		<b>UL-8</b>  3/1/11
		OUTWARD 75 LBS./SQ. FT.	UPWARD 125 LBS./SQ. FT.	

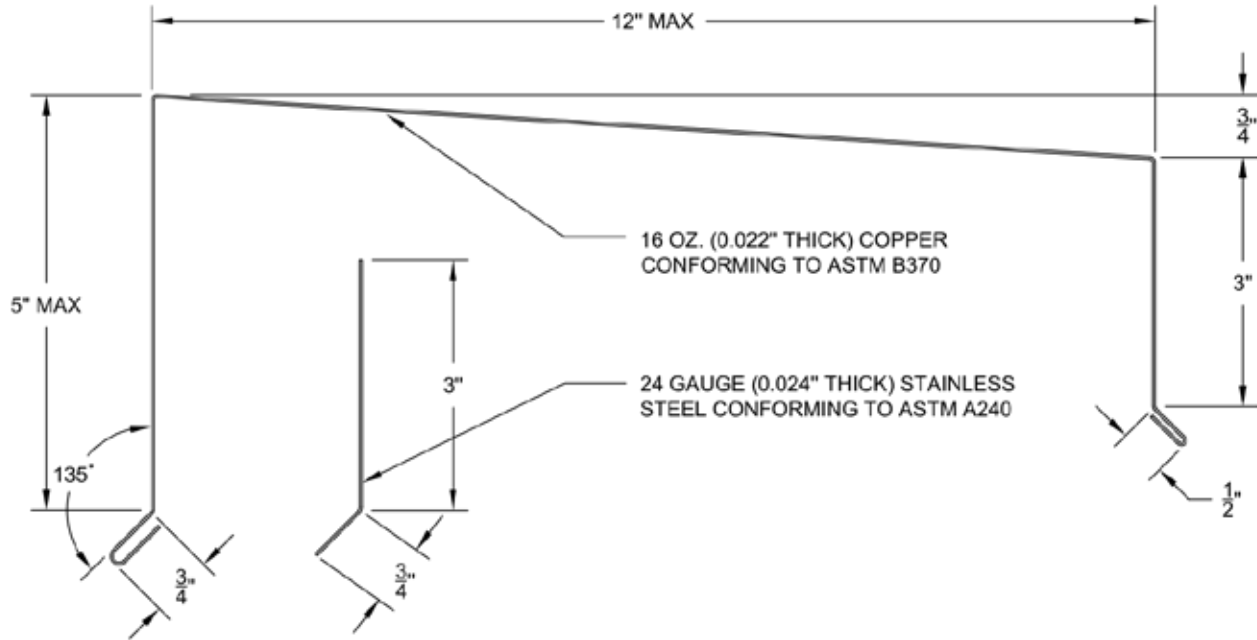

**FABRICATION**

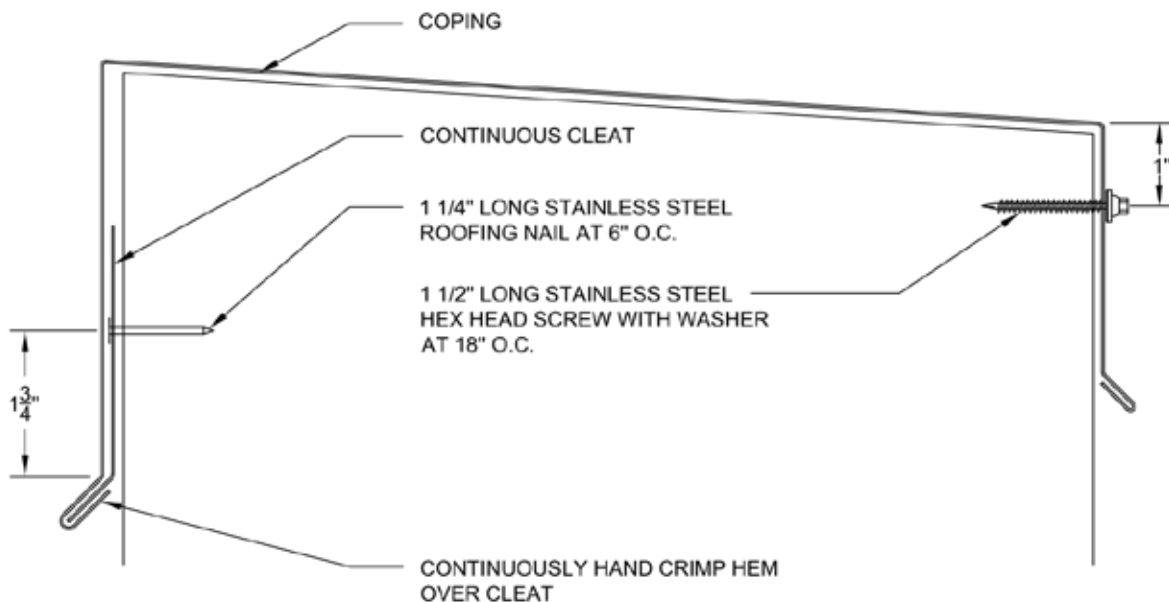

**INSTALLATION**

<b>THE NRCA ROOFING MANUAL</b> CONSTRUCTION DETAIL C-2	<b>COPING</b> • 16 OZ. COPPER • 24 GA. STAINLESS STEEL CLEAT • CONTINUOUS FRONT FACE CLEAT AND GASKETED BACK FACE FASTENER	<b>ANSI/SPRI ES-1 TESTED RESISTANCE</b>		<b>UL-8A</b>  8/1/12
		OUTWARD 75 LBS./SQ. FT.	UPWARD 125 LBS./SQ. FT.	

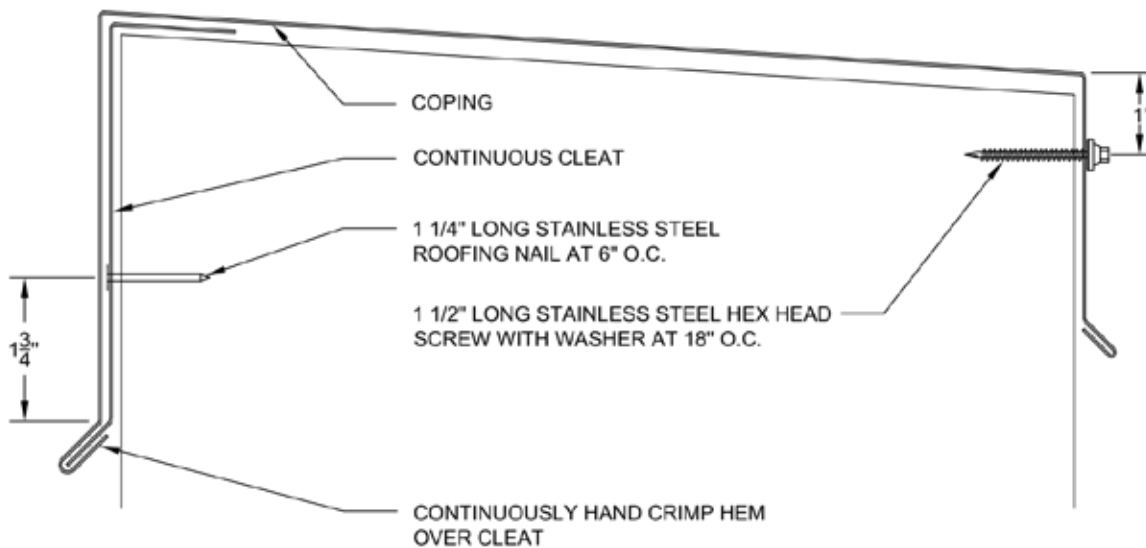
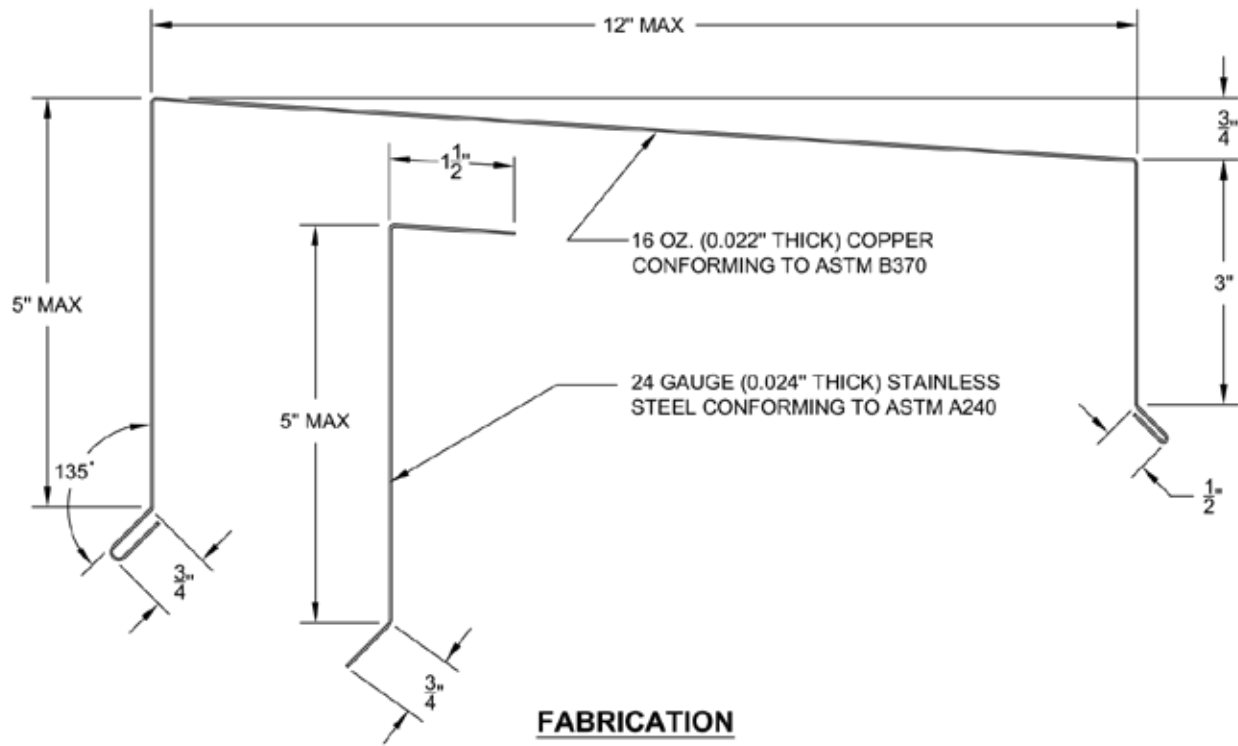

<b>THE NRCA ROOFING MANUAL</b> CONSTRUCTION DETAIL C-1	<b>COPING</b> <ul style="list-style-type: none"> <li>• 20 OZ. COPPER</li> <li>• 24 GA. STAINLESS STEEL CLEAT</li> <li>• CONTINUOUS FRONT FACE CLEAT AND GASKETED BACK FACE FASTENER</li> </ul>	<b>ANSI/SPRI ES-1 TESTED RESISTANCE</b>		<b>UL-9</b>  3/1/11
		OUTWARD 150 LBS./SQ. FT.	UPWARD 250 LBS./SQ. FT.	

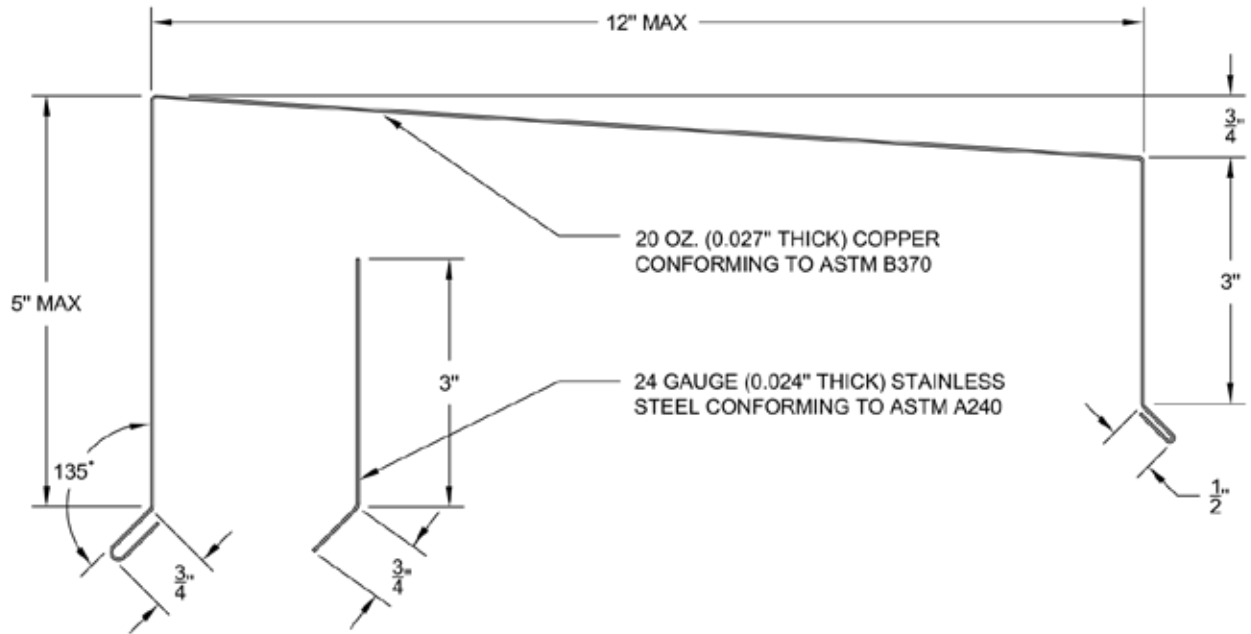

**FABRICATION**

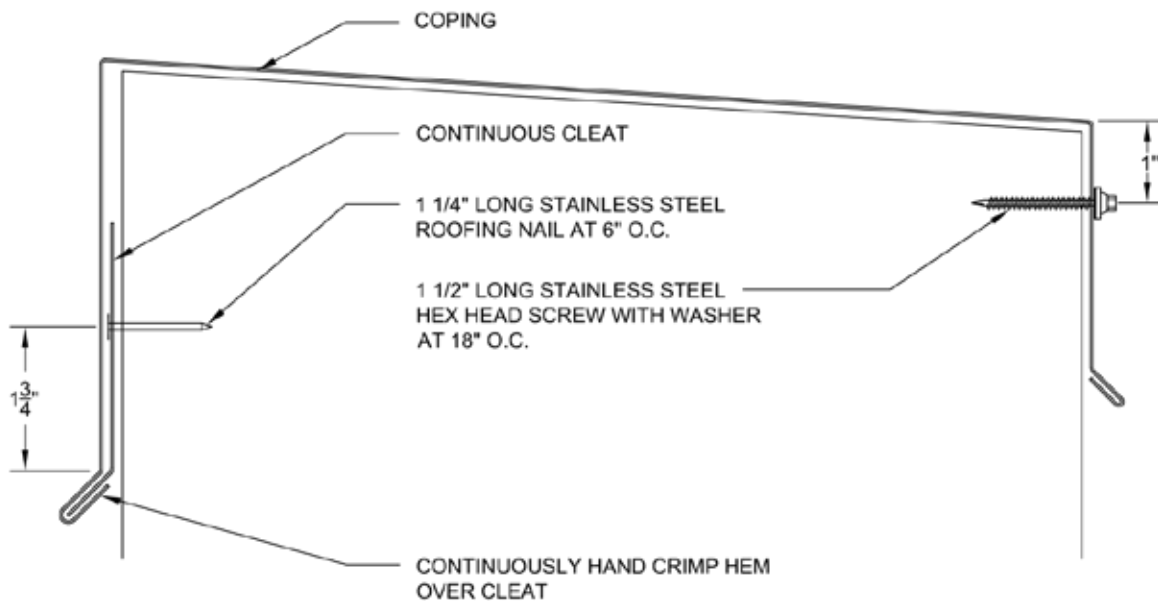

**INSTALLATION**

<b>THE NRCA ROOFING MANUAL</b> CONSTRUCTION DETAIL C-2	<b>COPING</b> • 20 OZ. COPPER • 24 GA. STAINLESS STEEL CLEAT • CONTINUOUS FRONT FACE CLEAT AND GASKETED BACK FACE FASTENER	<b>ANSI/SPRI ES-1 TESTED RESISTANCE</b>		<b>UL-9A</b>  8/1/12
		OUTWARD 150 LBS./SQ. FT.	UPWARD 250 LBS./SQ. FT.	

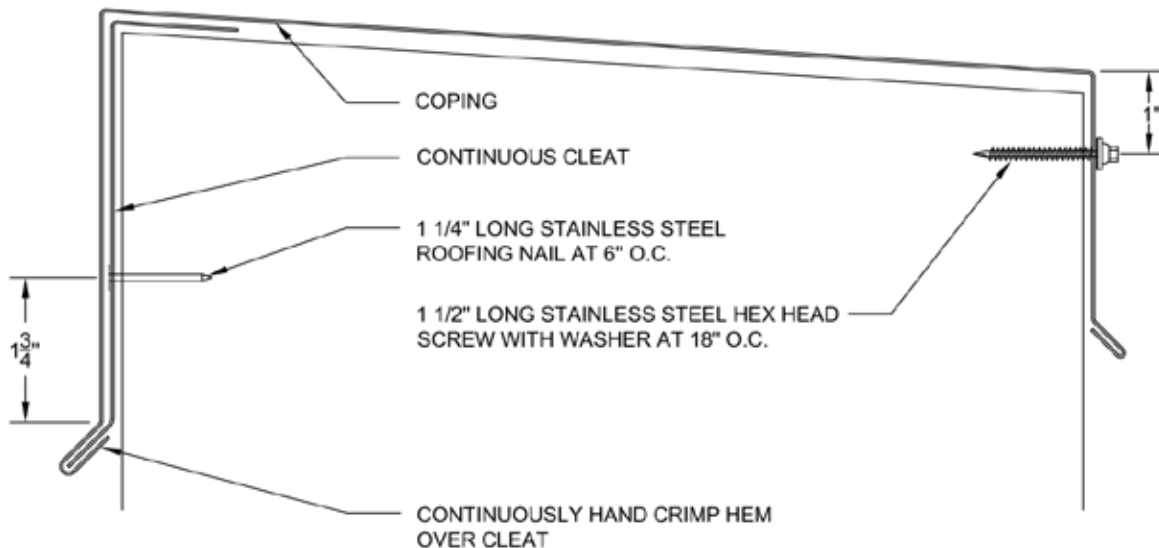
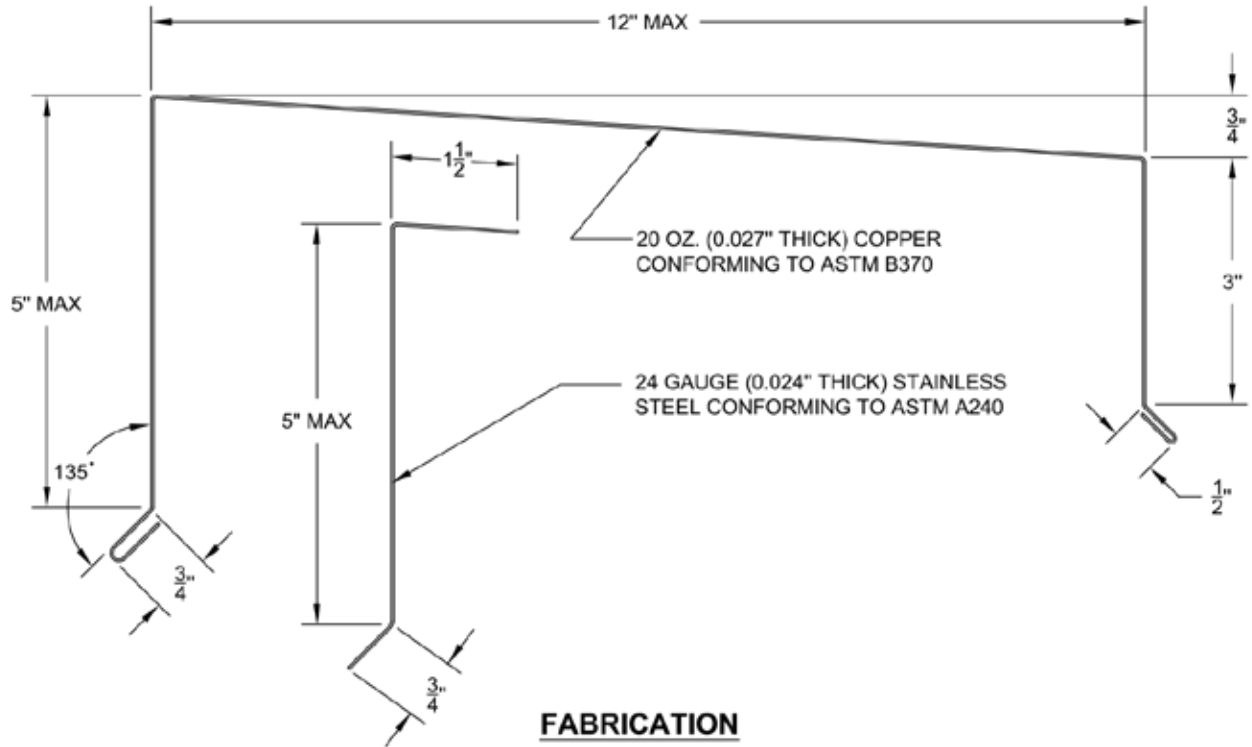

<b>THE NRCA ROOFING MANUAL</b> CONSTRUCTION DETAIL C-1	<b>COPING</b> <ul style="list-style-type: none"> <li>• 24 GA. STEEL</li> <li>• 22 GA. STEEL CLEAT</li> <li>• CONTINUOUS FRONT FACE CLEAT AND GASKETED BACK FACE FASTENER</li> </ul>	<b>ANSI/SPRI ES-1 TESTED RESISTANCE</b>		<b>UL-38</b>  8/31/17
		OUTWARD 104 LBS./SQ. FT.	UPWARD 180 LBS./SQ. FT.	

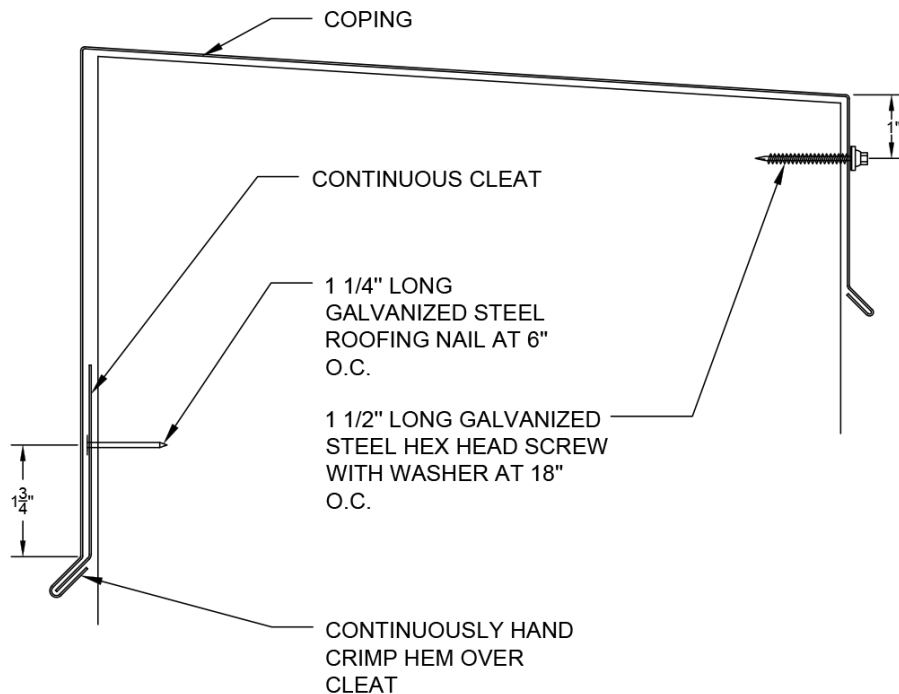
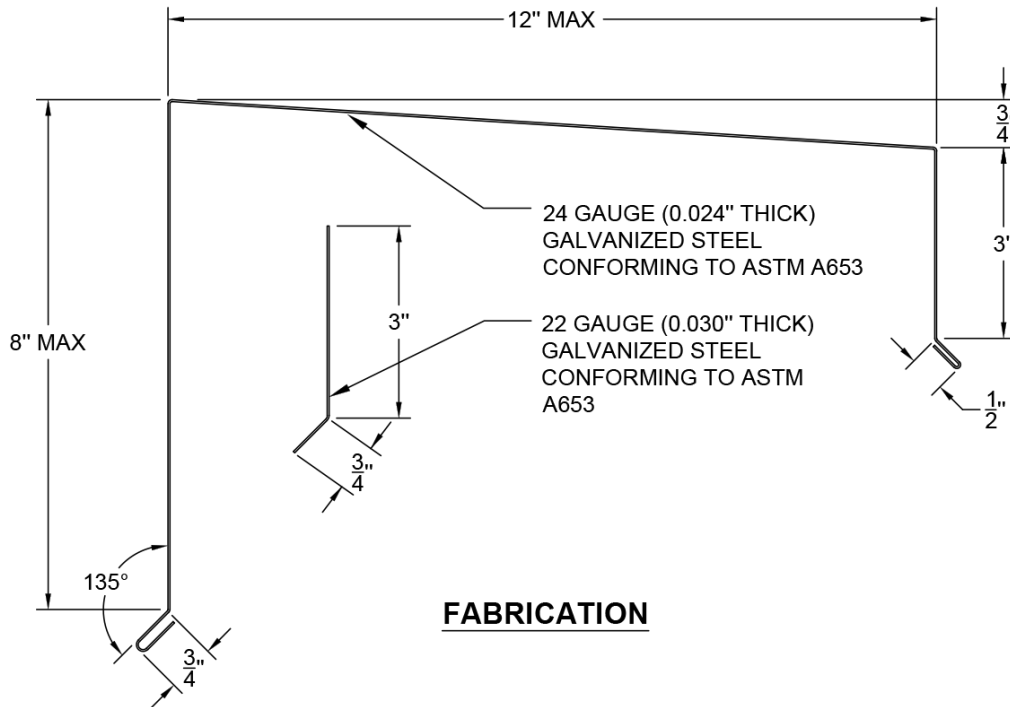

<b>THE NRCA ROOFING MANUAL</b> CONSTRUCTION DETAIL C-1	<b>COPING</b> <ul style="list-style-type: none"> <li>• 0.040" ALUMINUM</li> <li>• 0.050" ALUMINUM CLEAT</li> <li>• CONTINUOUS FRONT FACE CLEAT AND GASKETED BACK FACE FASTENER</li> </ul>	<b>ANSI/SPRI ES-1 TESTED RESISTANCE</b>		<b>UL-39</b>  8/31/17
		OUTWARD 127 LBS./SQ. FT.	UPWARD 220 LBS./SQ. FT.	

