

THE NRCA ROOFING MANUAL CONSTRUCTION DETAIL C-1	COPING • 24 GA. STEEL • 22 GA. STEEL CLEAT • CONTINUOUS FRONT FACE CLEAT AND GASKETED BACK FACE FASTENER	ANSI/SPRI ES-1 TESTED RESISTANCE		UL-1 10/30/15
		OUTWARD 190 LBS./SQ. FT.	UPWARD 310 LBS./SQ. FT.	

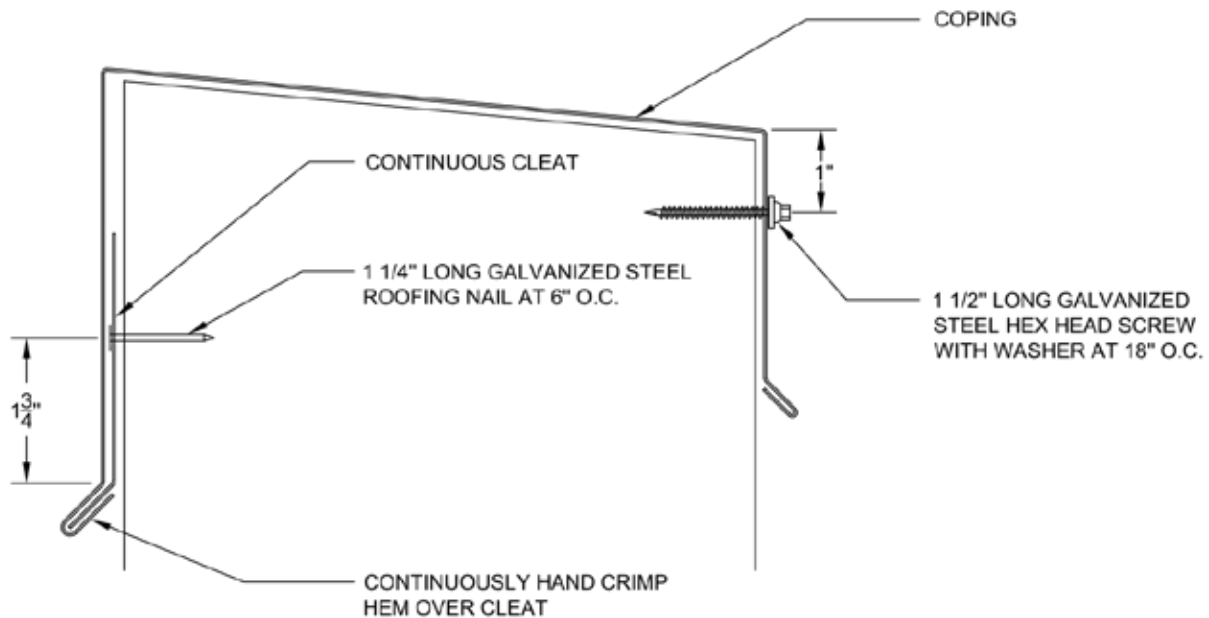

THE NRCA ROOFING MANUAL CONSTRUCTION DETAIL C-2	COPING <ul style="list-style-type: none"> • 24 GA. STEEL • 22 GA. STEEL CLEAT • CONTINUOUS FRONT FACE CLEAT AND GASKETED BACK FACE FASTENER 	ANSI/SPRI ES-1 TESTED RESISTANCE		UL-1A 10/30/15
		OUTWARD 190 LBS./SQ. FT.	UPWARD 310 LBS./SQ. FT.	

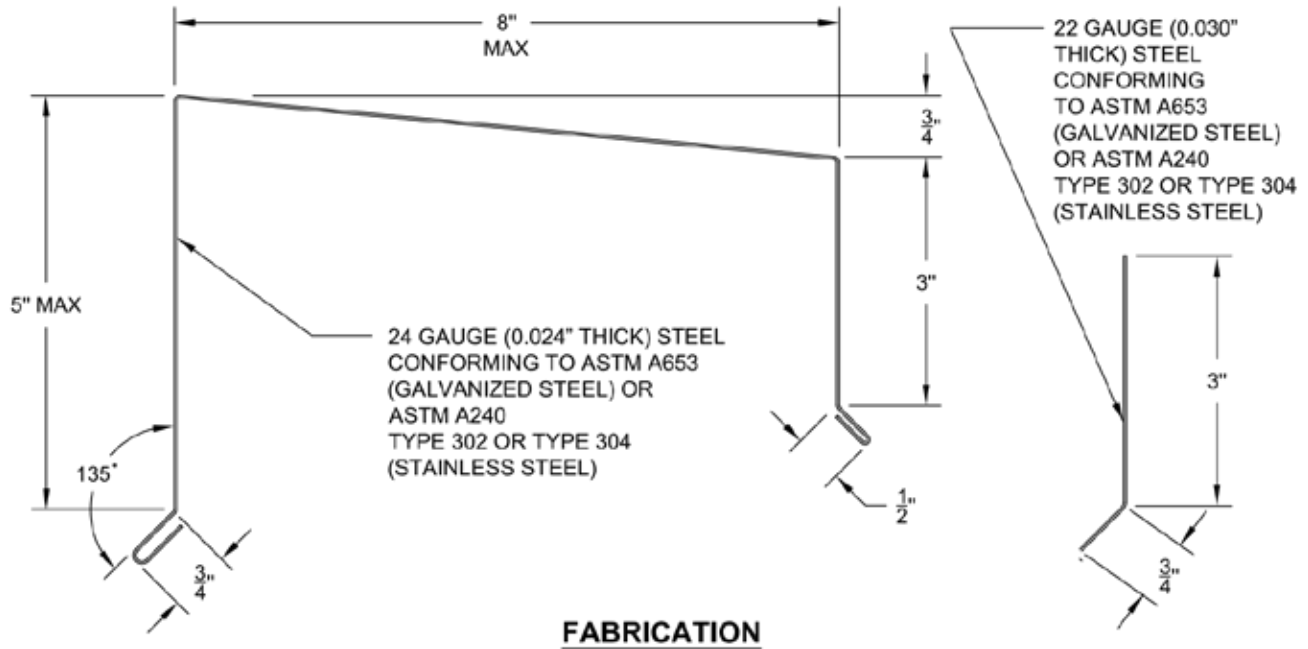
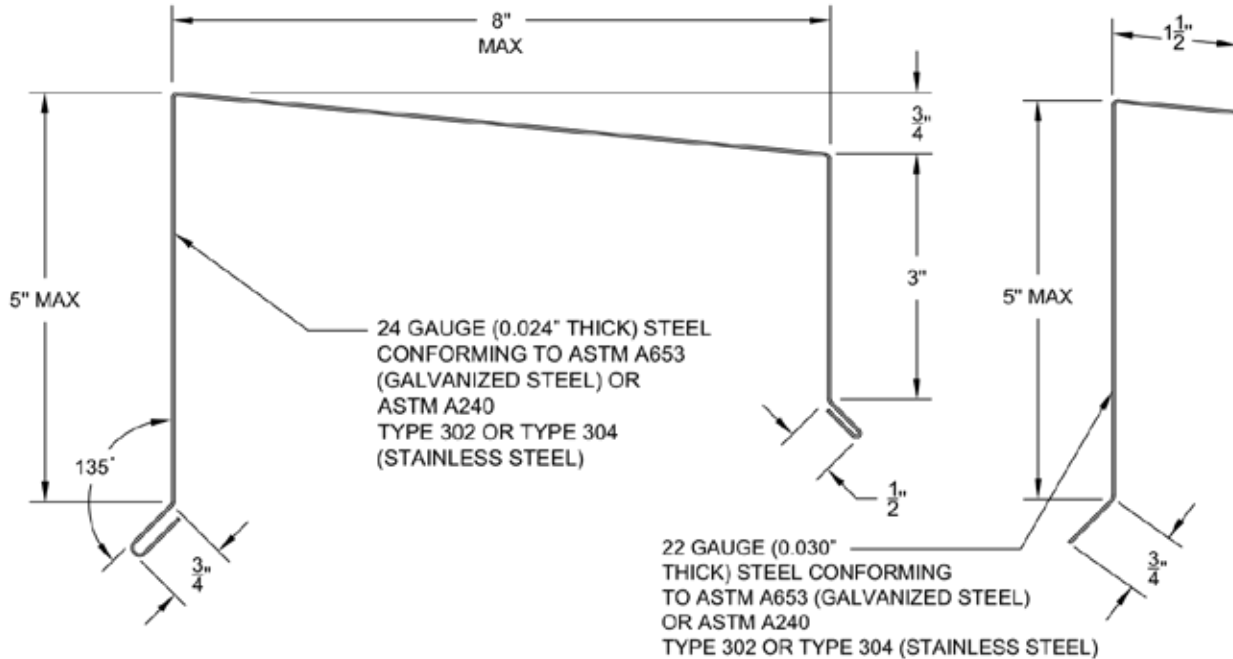

FABRICATION

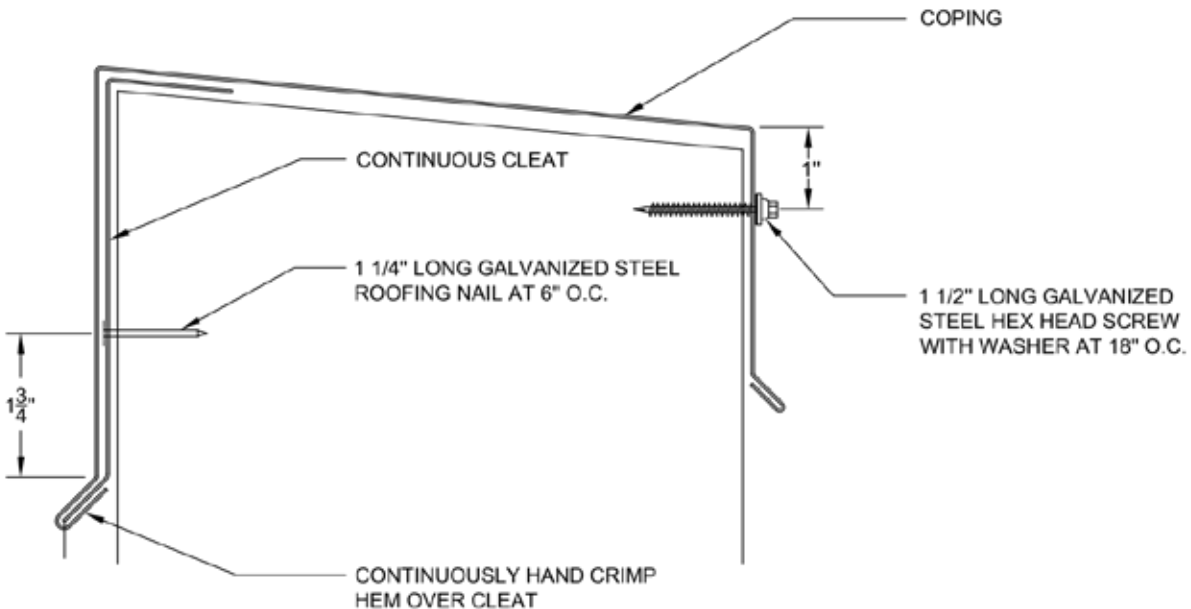

INSTALLATION

THE NRCA ROOFING MANUAL CONSTRUCTION DETAIL C-1	COPING • 0.040" ALUMINUM • 0.040" ALUMINUM CLEAT • CONTINUOUS FRONT FACE CLEAT AND GASKETED BACK FACE FASTENER	ANSI/SPRI ES-1 TESTED RESISTANCE	UL-2 2/6/17
		OUTWARD 150 LBS./SQ. FT. UPWARD 250 LBS./SQ. FT.	

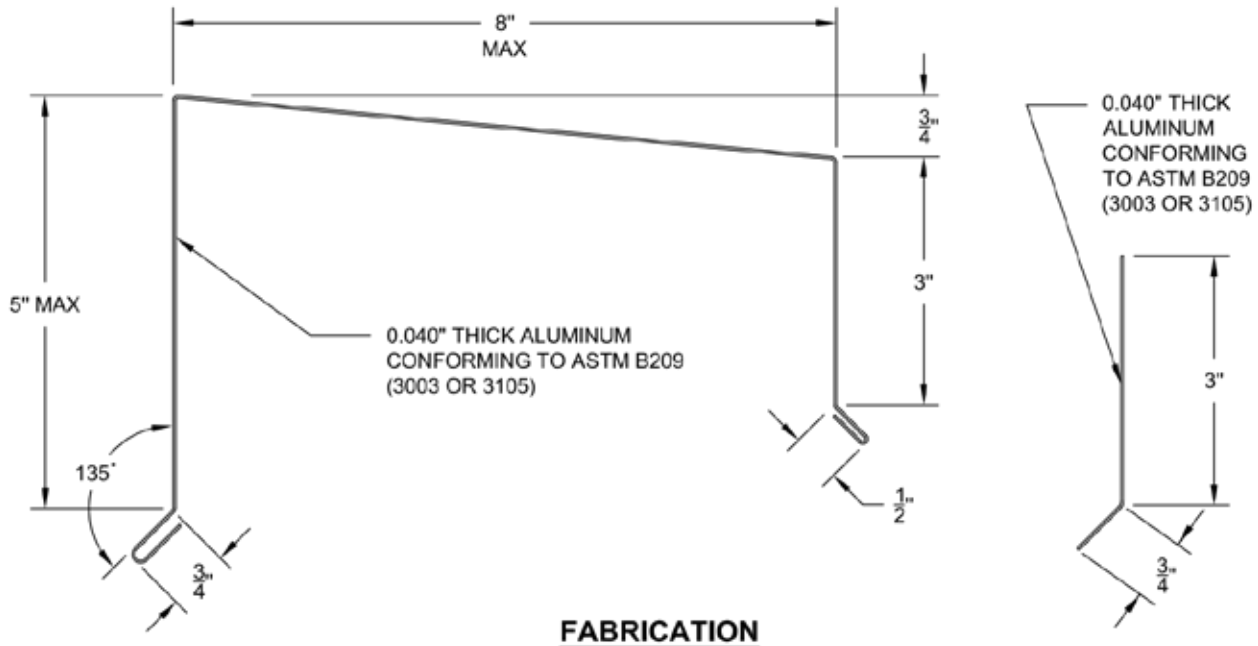

FABRICATION

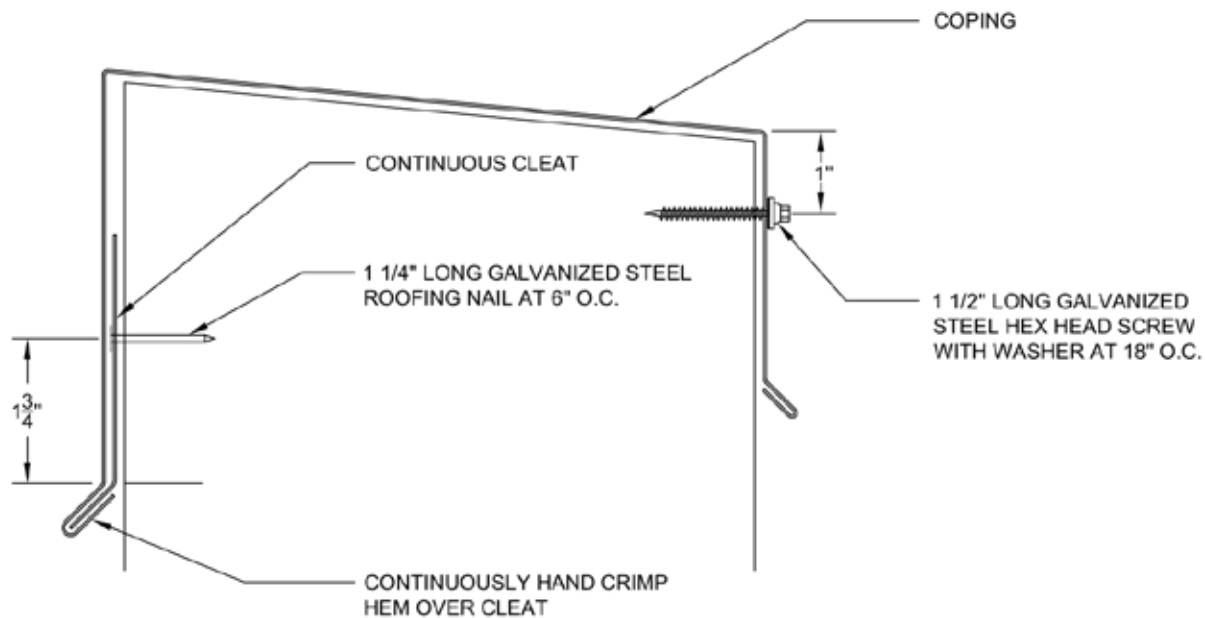

INSTALLATION

THE NRCA ROOFING MANUAL CONSTRUCTION DETAIL C-2	COPING <ul style="list-style-type: none"> • 0.040" ALUMINUM • 0.040" ALUMINUM CLEAT • CONTINUOUS FRONT FACE CLEAT AND GASKETED BACK FACE FASTENER 	ANSI/SPRI ES-1 TESTED RESISTANCE		UL-2A 2/6/17
		OUTWARD 150 LBS./SQ. FT.	UPWARD 250 LBS./SQ. FT.	

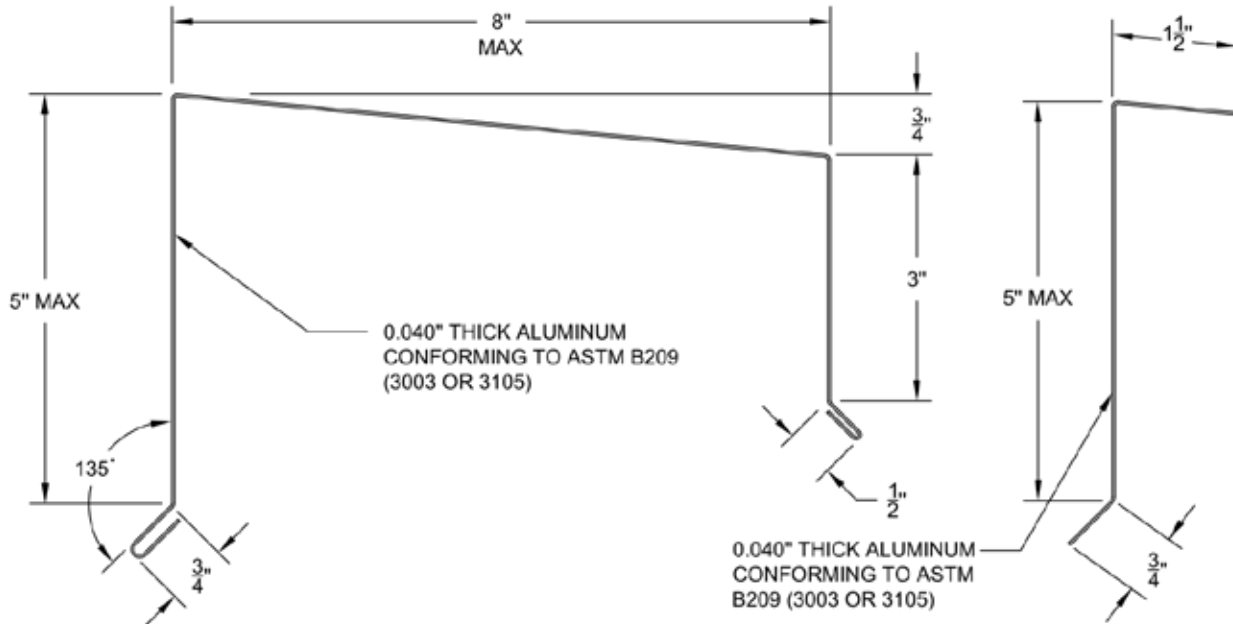

FABRICATION

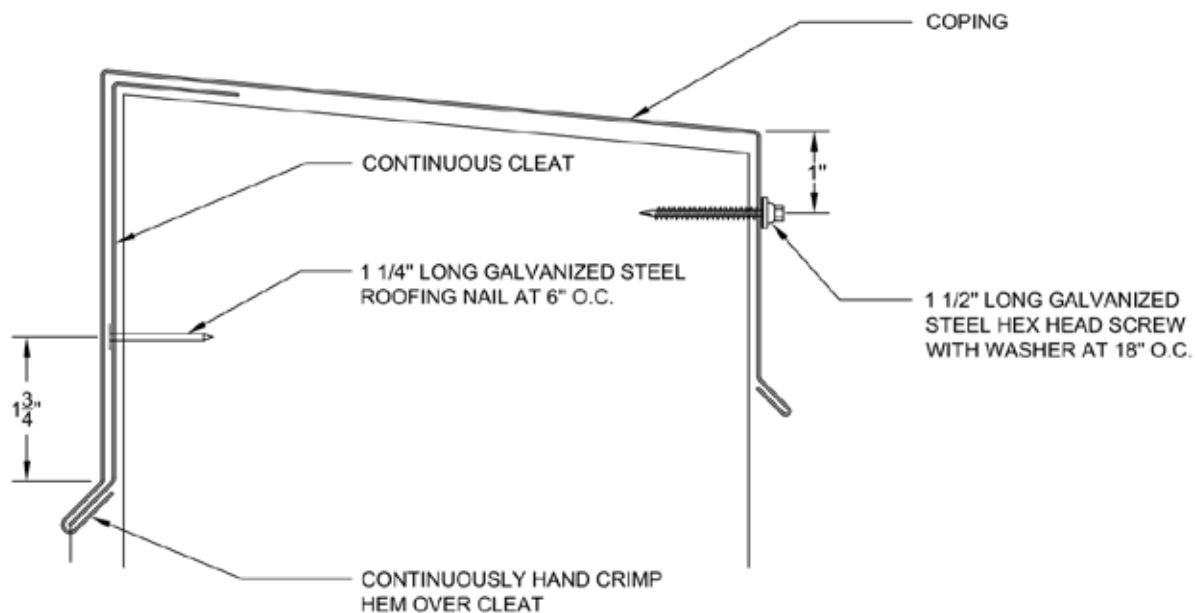

INSTALLATION

THE NRCA ROOFING MANUAL CONSTRUCTION DETAIL C-1	COPING • 20 OZ. COPPER • 24 GA. STAINLESS STEEL CLEAT • CONTINUOUS FRONT FACE CLEAT AND GASKETED BACK FACE FASTENER	ANSI/SPRI ES-1 TESTED RESISTANCE		UL-3 3/1/11
		OUTWARD 135 LBS./SQ. FT.	UPWARD 220 LBS./SQ. FT.	

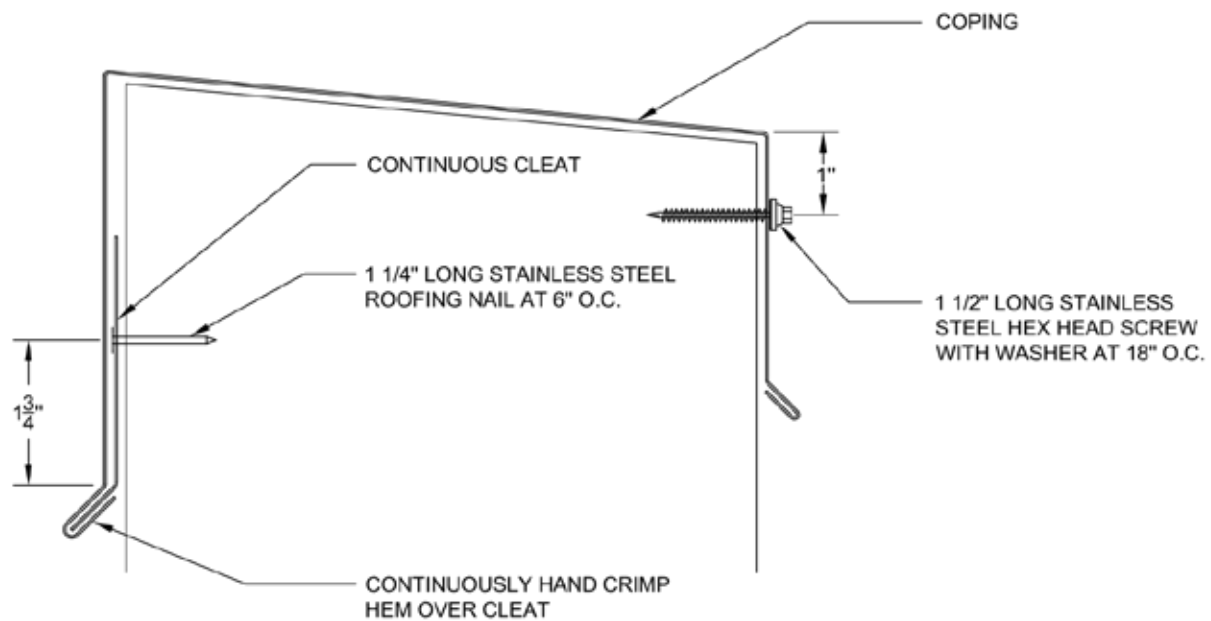
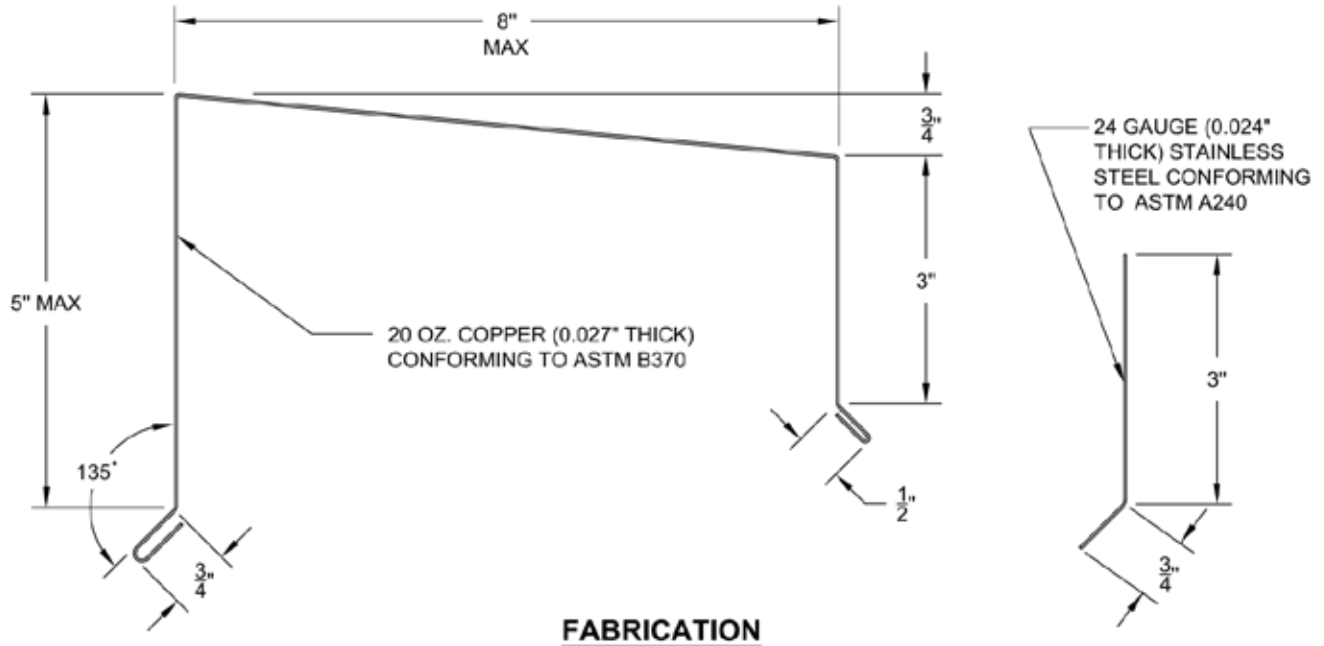

THE NRCA ROOFING MANUAL CONSTRUCTION DETAIL C-2	COPING <ul style="list-style-type: none"> • 20 OZ. COPPER • 24 GA. STAINLESS STEEL CLEAT • CONTINUOUS FRONT FACE CLEAT AND GASKETED BACK FACE FASTENER 	ANSI/SPRI ES-1 TESTED RESISTANCE		UL-3A 8/1/12
		OUTWARD 135 LBS./SQ. FT.	UPWARD 220 LBS./SQ. FT.	

